



PROPRIETARY NOTE

THIS SPECIFICATION IS THE PROPERTY OF HYDIS AND SHALL NOT BE REPRODUCED OR COPIED WITHOUT THE WRITTEN PERMISSION OF HYDIS AND MUST BE RETURNED TO HYDIS UPON ITS REQUEST

TITLE : : HT121X01-101
Preliminary Product Specification
for NuAsia
Rev. P0

HYDIS Technologies

SPEC. NUMBER	PRODUCT GROUP	REV.	ISSUE DATE	PAGE
B2005-C001-C(1/3)	TFT-LCD PRODUCTS	P0	2008. 11.28	1 / 26

B2005-C001-C(1/3)

A4(210 X 297)



HYDIS

PRODUCT GROUP

REV

ISSUE DATE

TFT-LCD PRODUCT

P0

2008.11.28

REVISION HISTORY

REV.	ECN NO.	DESCRIPTION OF CHANGES	DATE	PREPARED
PO		.Initial Release	08.11.28	S.W.Kang

SPEC. NUMBER

SPEC. TITLE

HT121X01-101 Pre-Product Specification for NuAsia

PAGE

2 / 26

B2005-C001-C(2/3)

A4(210 X 297)



HYDIS

PRODUCT GROUP

REV

ISSUE DATE

TFT-LCD PRODUCT

P0

2008.11.28

Contents

		Page
1.0	General Description ..	4
2.0	Absolute Maximum ratings.....	6
3.0	Electrical specifications	7
4.0	Optical specifications	8
5.0	Interface Connection	10
6.0	Signal Timing Specification	12
7.0	Signal Timing waveforms	14
8.0	Input Signals, Display Colors & Gray Scale of Colors	15
9.0	Power Sequence	16
10.0	Mechanical Characteristics	17
11.0	Reliability Test	18
12.0	Handling & Cautions.....	19
13.0	Packing	20
14.0	Environment & Safety.....	21
15.0	Appendix	23

SPEC. NUMBER

SPEC. TITLE

HT121X01-101 Pre-Product Specification for NuAsia

PAGE

3 / 26

B2005-C001-C(3/3)

A4(210 X 297)

1.0 GENERAL DESCRIPTION

1.1 Introduction

HT121X01-101 is a color active matrix TFT LCD module using amorphous silicon TFT's (Thin Film Transistors) as an active switching devices. This module has a 12.1 inch diagonally measured active area with XGA resolutions (1024 horizontal by 768 vertical pixel array). Each pixel is divided into RED, GREEN, BLUE dots which are arranged in vertical stripe and this module can display 262,144 colors. The TFT-LCD panel used for this module is a low reflection and higher color type.

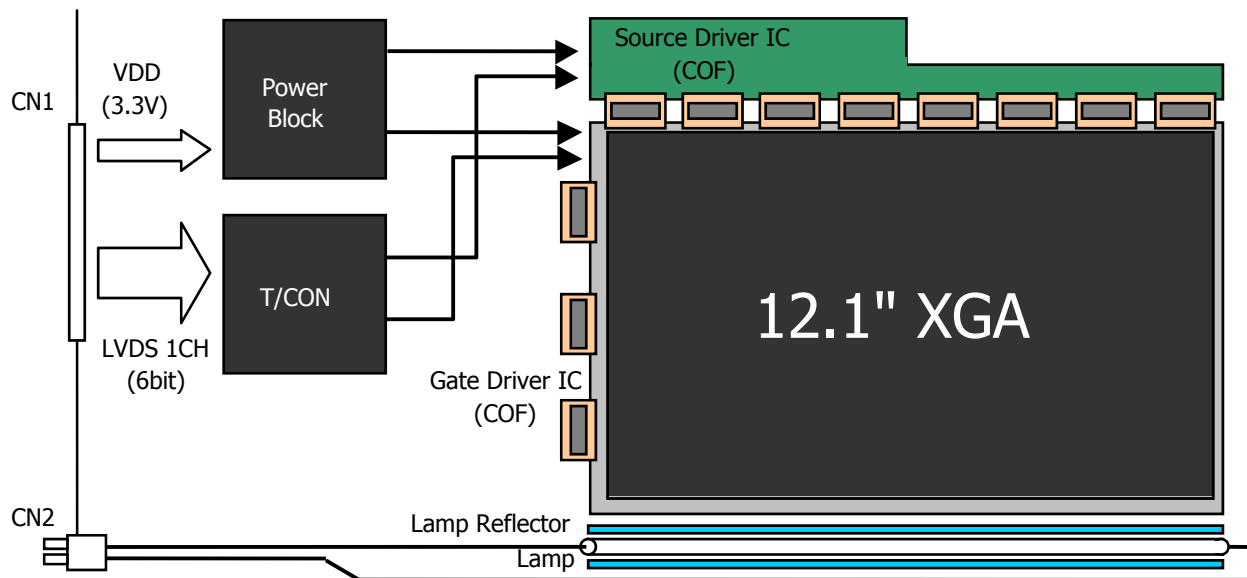

1.2 Features

- Thin and light weight
- 3.3 V power supply
- Low driving voltage and low power consumption
- 1 Channel LVDS Interface
- Single CCFL (Bottom side/Horizontal Direction)
- 262,144 colors
- Data enable signal mode
- Side Mounting Frame
- Al Bezel
- On Board EDID chip
- RoHS

**HYDIS****PRODUCT GROUP**

REV

ISSUE DATE

TFT-LCD PRODUCT

P0

2008.11.28

1.3 Application

- Notebook PC

1.4 General Specifications

Parameter	Specification	Unit	Remarks
Active area	245.76 (H) × 184.32 (V)	mm	
Number of pixels	1024 (H) × 768 (V)	pixels	
Pixel pitch	0.240 (H) × 0.240 (V)	mm	
Pixel arrangement	RGB Vertical stripe		
Display colors	262,144	colors	
Display mode	Normally white		
Dimensional outline	261.0±0.4(W) × 198.0±0.4(V) × 4.7(D) Typ./5.0(D)Max	mm	
Weight	275 (Typ.) / 285 (Max.)	g	
Back-light	CCFL, Horizontal-lamp type		Note 1

Note 1: CCFL (Cold Cathode Fluorescent Lamp)

SPEC. NUMBER

SPEC. TITLE

HT121X01-101 Pre-Product Specification for NuAsia

PAGE

5 / 26

B2005-C001-C(3/3)

A4(210 X 297)

2.0 ABSOLUTE MAXIMUM RATINGS

The followings are maximum values which, if exceed, may cause faulty operation or damage to the unit.

< Table 2. Absolute Maximum Ratings >

Parameter	Symbol	Min.	Max.	Unit	Remarks
Logic Power Supply	V_{DD}	VSS-0.3	4.0	V	Ta = 25 ± 2 °C
Logic Input Voltage	V_{IN}	VSS-0.3	$V_{DD}+0.3$	V	
Back-light Lamp Current	IBL	2.0	7.0	mA	
Back-light Frequency	FBL	45	80	KHz	
Operating Temperature	T_{OP}	0	+50	°C	Note 1
Storage Temperature	T_{SP}	-20	+60	°C	

Note 1. Temperature and relative humidity range are shown in the figure below.

* 90 [%] RH Max. ($40^{\circ}\text{C} \geq T_a$)

* Maximum wet-bulb temperature at 39 °C or less. ($T_a > 40^{\circ}\text{C}$) No condensation

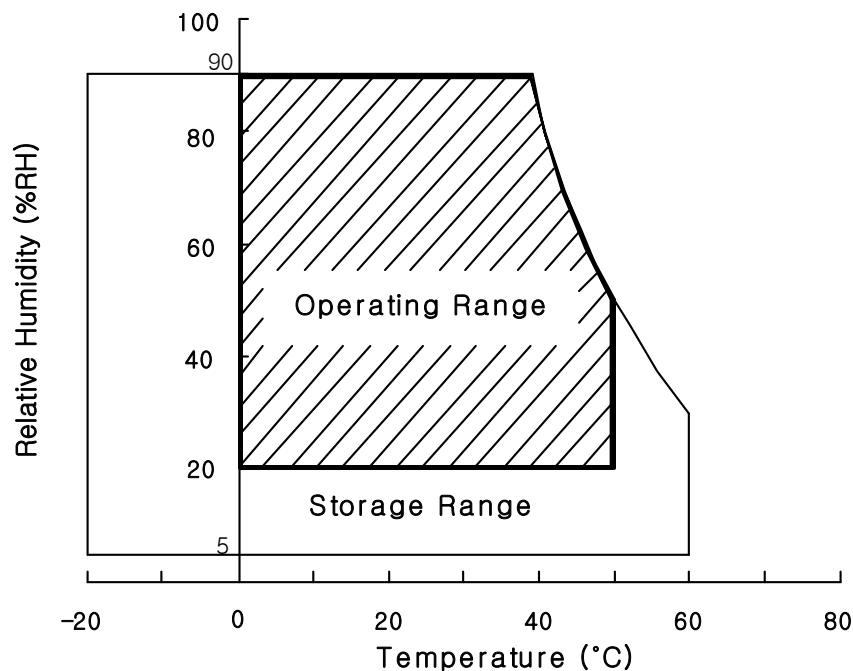



PRODUCT GROUP

REV

ISSUE DATE

TFT-LCD PRODUCT

P0

2008.11.28

3.0 ELECTRICAL SPECIFICATIONS

3.1 Electrical Specifications

< Table 3. Electrical specifications >

[Ta = 25±2℃]

Parameter		Min.	Typ.	Max.	Unit	Remarks
Power Supply Voltage	V _{DD}	3.0	3.3	3.6	V	Note1
Power Supply Current	I _{DD}	-	280	485	mA	Note1
CCFL Ignition Time	t	-	-	1	sec	
High Level Differential Input Signal Voltage	V _{IH}	-	-	+100	mV	
Low Level Differential Input Signal Voltage	V _{IL}	-100	-	-	mV	
Back-light Lamp Voltage	V _{BL}	-	600	-	V _{rms}	Note2
Back-light Lamp Current	I _{BL}	-	5.0	6.0	mA	
Back-light Lamp operating Frequency	F _L	45	58	80	KHz	One Lamp, Note3
Lamp Start Voltage		1,080	-	-	V _{rms}	At Ta=25℃, Note4
		1,300	-	-	V _{rms}	At Ta=0℃, Note4
Lamp Life		12,000	15,000	-	Hrs	I _{BL} = 5mA, Note5
Power Consumption	P _D	-	0.9	1.6	W	Note1
	P _{BL}	2.0	3.0	3.5	W	I _{BL} = 5mA, Note6
	P _{total}	-	3.9	5.1	W	

- Notes :
- The supply voltage is measured and specified at the interface connector of LCM.
The current draw and power consumption specified is for 3.3V @ 50Hz.
a) Typ: Windows XP desktop Pattern b) Max: V2 Skip Pattern (L128)
 - Reference value, which is measured with Samsung Electric SIC-180 Inverter.
(VBL Min is value at IBL Min and VBL Max is value at IBL Max)
 - The lamp frequency should be selected as different as possible from the horizontal synchronous frequency and its harmonics to avoid interference which may cause line flow on the display.
 - For starting the backlight unit, the output voltage of DC/AC's transformer should be larger than the minimum lamp starting voltage.(1,080 Vrms at 25 °C & 1,300 Vrms at 0 °C)
If an inverter has shutdown function it should keep its output for more than 1 second even if the lamp connector open. Otherwise the lamps may not to be turned on.
 - End of Life shall be determined by the time when any of the following is satisfied under continuous lighting at 25℃ and IBL = 5.0[mA].
• Intensity drops to 50% of the Initial Value.
 - Calculated value for reference (VBL × IBL)

SPEC. NUMBER

SPEC. TITLE

HT121X01-101 Pre-Product Specification for NuAsia

PAGE

7 / 26

4.0 OPTICAL SPECIFICATION

4.1 Overview

The test of Optical specifications shall be measured in a dark room (ambient luminance ≤ 1 lux and temperature = $25 \pm 2^\circ\text{C}$) with the equipment of Luminance meter system (Goniometer system and TOPCONE BM-5) and test unit shall be located at an approximate distance 50cm from the LCD surface at a viewing angle of θ and Φ equal to 0° . We refer to $\theta_{\Phi=0}$ ($=\theta_3$) as the 3 o'clock direction (the "right"), $\theta_{\Phi=90}$ ($=\theta_{12}$) as the 12 o'clock direction ("upward"), $\theta_{\Phi=180}$ ($=\theta_9$) as the 9 o'clock direction ("left") and $\theta_{\Phi=270}$ ($=\theta_6$) as the 6 o'clock direction ("bottom"). While scanning θ and/or Φ , the center of the measuring spot on the Display surface shall stay fixed. The backlight should be operating for 30 minutes prior to measurement... VDD shall be $3.3 \pm 0.3\text{V}$ at 25°C . Optimum viewing angle direction is 6 o'clock.

4.2 Optical Specifications

<Table 4. Optical Specifications>

Parameter		Symbol	Condition	Min.	Typ.	Max.	Unit	Remark
Viewing Angle range	Horizontal	θ_3	CR > 10	-	45	-	Deg.	Note 1
		θ_9		-	45	-	Deg.	
	Vertical	θ_{12}		-	20	-	Deg.	
		θ_6		-	40	-	Deg.	
Luminance Contrast ratio		CR	$\theta = 0^\circ$	250	300	-		Note 2
Luminance of White	1 Point Center	Y_w	$\theta = 0^\circ$ IBL = 6mA	-	170	-	cd/m ²	Note 3
White Luminance uniformity	5 Points	ΔY_5		80	-	-	%	Note 4
	13 Points	ΔY_{13}		65	-	-		
White Chromaticity		x_w	$\theta = 0^\circ$	0.285	0.313	0.341		Note 5
		y_w		0.309	0.329	0.349		
Reproduction Of color	Red	x_R	$\theta = 0^\circ$	0.539	0.569	0.599		
		y_R		0.302	0.332	0.362		
	Green	x_G		0.282	0.312	0.342		
		y_G		0.514	0.544	0.574		
	Blue	x_B		0.119	0.149	0.179		
		y_B		0.102	0.132	0.172		
Response Time	Rise	T_r	Ta = 25°C $\theta = 0^\circ$	-	10	20	ms	Note 6
	Decay	T_d		-	20	40	ms	
Cross Talk		CT	$\theta = 0^\circ$	-	-	2.0	%	Note 7

 HYDIS	PRODUCT GROUP	REV	ISSUE DATE
	TFT-LCD PRODUCT	P0	2008.11.28

Note :

1. Viewing angle is the angle at which the contrast ratio is greater than 10. The viewing are determined for the horizontal or 3, 9 o'clock direction and the vertical or 6, 12 o'clock direction with respect to the optical axis which is normal to the LCD surface (see FIGURE 1 shown in Appendix).
2. Contrast measurements shall be made at viewing angle of $\Theta = 0^\circ$ and at the center of the LCD surface. Luminance shall be measured with all pixels in the view field set first to white, then to the dark (black) state. (See FIGURE 1 shown in Appendix) Luminance Contrast Ratio (CR) is defined mathematically.

$$CR = \frac{\text{Luminance when displaying a white raster}}{\text{Luminance when displaying a black raster}}$$

3. Center Luminance of white is defined as luminance values of center 1 point across the LCD surface. Luminance shall be measured with all pixels in the view field set first to white. This measurement shall be taken at the locations shown in FIGURE 2 for a total of the measurements per display. And the typical luminance is measured at 6mA lamp current.
4. The White luminance uniformity on LCD surface is then expressed as : $\Delta Y = \text{Minimum Luminance of 5(or 13) points} / \text{Maximum Luminance of 5(or 13) points}$ (see FIGURE 2 shown in Appendix).
5. The color chromaticity coordinates specified in Table 4 shall be calculated from the spectral data measured with all pixels first in red, green, blue and white. Measurements shall be made at the center of the panel.
6. The electro-optical response time measurements shall be made as FIGURE 3 shown in Appendix by switching the "data" input signal ON and OFF. The times needed for the luminance to change from 10% to 90% is T_r , and 90% to 10% is T_d .
7. Cross-Talk of one area of the LCD surface by another shall be measured by comparing the luminance (Y_A) of a 25mm diameter area, with all display pixels set to a gray level, to the luminance (Y_B) of that same area when any adjacent area is driven dark. (See FIGURE 4 shown in Appendix).

SPEC. NUMBER	SPEC. TITLE HT121X01-101 Pre-Product Specification for NuAsia	PAGE 9 / 26
--------------	--	----------------

5.0 INTERFACE CONNECTION.

5.1 Electrical Interface Connection

<Table 5. Pin Assignments for the Interface Connector>

CN1	Interface connector	Hirose/DF19L-20P-1H or equivalent
	User side connector	Hirose/DF19G-20S-1C or equivalent

Pin No	Symbol	Function	Remark
1	VSS	Ground	
2	VDD1	Power Supply: +3.3V	
3	VDD2	Power Supply: +3.3V	
4	Vdd_EDID	EDID +3.3V	
5	NC	Reserved	
6	Clk_EDID	EDID Clk	
7	Clk_Data	EDID Data	
8	RIN0-	LVDS Negative data signal (-)	Tx pin # 48
9	RIN0+	LVDS Positive data signal (+)	Tx pin # 47
10	VSS	Ground	
11	RIN1-	LVDS Negative data signal (-)	Tx pin # 46
12	RIN1+	LVDS Positive data signal (+)	Tx pin # 45
13	VSS	Ground	
14	RIN2-	LVDS Negative data signal (-)	Tx pin # 42
15	RIN2+	LVDS Positive data signal (+)	Tx pin # 41
16	VSS	Ground	
17	RCLKIN-	LVDS Negative clock signal (-)	Tx pin # 40
18	RCLKIN+	LVDS Positive clock signal (+)	Tx pin # 39
19	VSS	Ground	
20	VSS	Ground	



PRODUCT GROUP

REV

ISSUE DATE

TFT-LCD PRODUCT

P0

2008.11.28

5.2. Back-light Interface

CN2	Interface Connector	•: BHSR-02VS-1 (JST) or equivalent
-----	---------------------	------------------------------------

Pin No	INPUT	Function	Remarks
1	HOT	High voltage	Pink
2	COLD	Ground	Black

5.3. LVDS Interface

LVDS Transmitter: THC63LVDM83A or equivalent.

Input signal	Transmitter		Interface		DF19KR-20P-1H	Remark
	Pin No	Pin No	System (Tx)	TFT-LCD (Rx)	Pin No.	
R0	51	48 47	OUT0- OUT0+	IN0- IN0+	5 6	
R1	52					
R2	54					
R3	55					
R4	56					
R5	3					
G0	4	46 45	OUT1- OUT1+	IN1- IN1+	8 9	
G1	6					
G2	7					
G3	11					
G4	12					
G5	14					
B0	15	42 41	OUT2- OUT2+	IN2- IN2+	11 12	
B1	19					
B2	20					
B3	22					
B4	23					
B5	24					
HSYNC	27	40	CLKOUT-	CLKIN-	14	
VSYNC	28					
DE	30					
MCLK	31	39	CLKOUT+	CLKIN+	15	

SPEC. NUMBER

SPEC. TITLE

HT121X01-101 Pre-Product Specification for NuAsia

PAGE

11 / 26



5.4. Back-light Format

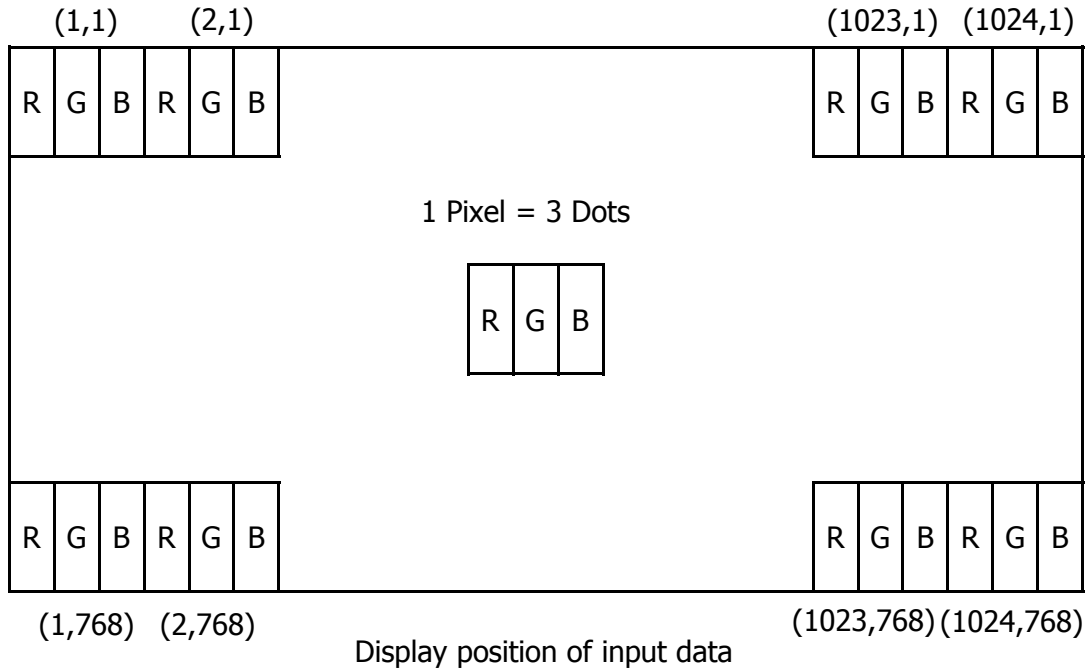

6.0. SIGNAL TIMING SPECIFICATIONS

6.1 The 12.1"XGA LCM is operated by the only DE mode (LVDS Transmitter Input)

Item		Symbols	Min	Typ	Max	Unit
Clock	Frequency	1/Tc	-	65	80	MHz
	High Time	Tch	4.5	-	-	ns
	Low Time	Tcl	4.5	-	-	ns
Data	Setup Time	Tds	2.7	-	-	ns
	Hold Time	Tdh	0	-	-	ns
Data Enable Setup Time		Tes	2.7	-	-	ns
Frame Period		Tv	772	806	1022	lines
Vertical Display Period		Tvd	768	768	768	lines
One Line Scanning Period		Th	1100	1344	2046	clocks
Horizontal Display Period		Thd	1024	1024	1024	clocks

6.2. LVDS Rx interface timing parameter

The specification of the LVDS Rx interface timing parameter

<LVDS Rx Interface Timing Specification>

Item	Symbol	Min	Typ	Max	Unit	Remark
CLKIN Period	tRCIP	12.5	15.38		nsec	
Input Data 0	tRIP0	-0.4	0.0	+0.4	nsec	
Input Data 1	tRIP1	tRICP/7-0.4	tRICP/7	tRICP/7+0.4	nsec	
Input Data 2	tRIP2	2 × tRICP/7-0.4	2 × tRICP/7	2 × tRICP/7+0.4	nsec	
Input Data 3	tRIP3	3 × tRICP/7-0.4	3 × tRICP/7	3 × tRICP/7+0.4	nsec	
Input Data 4	tRIP4	4 × tRICP/7-0.4	4 × tRICP/7	4 × tRICP/7+0.4	nsec	
Input Data 5	tRIP5	5 × tRICP/7-0.4	5 × tRICP/7	5 × tRICP/7+0.4	nsec	
Input Data 6	tRIP6	6 × tRICP/7-0.4	6 × tRICP/7	6 × tRICP/7+0.4	nsec	

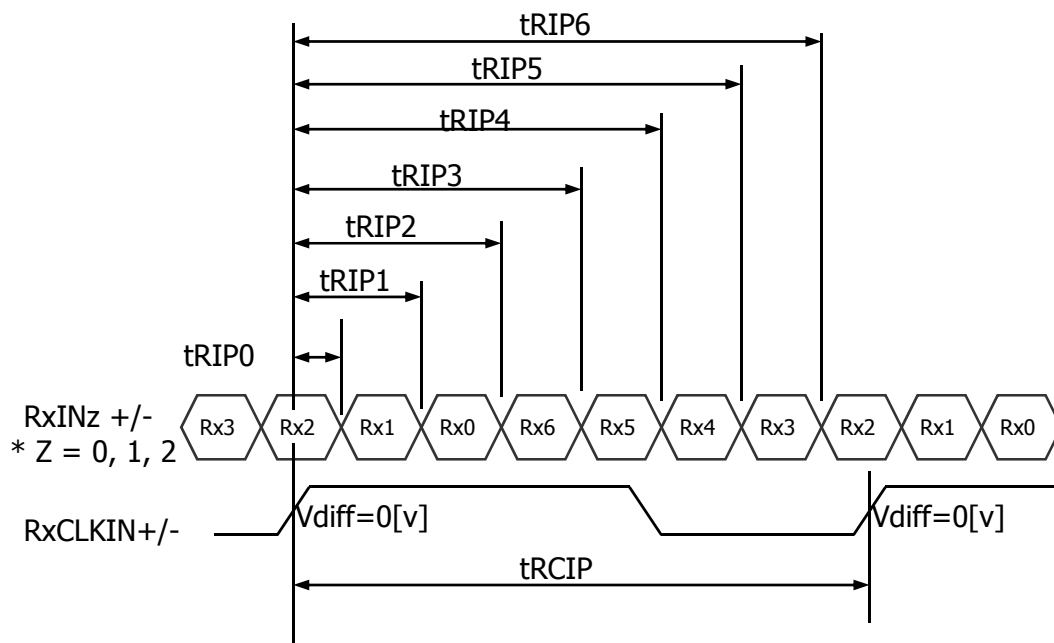

* Vdiff = (RINz+)-(RINz-), (RCLKIN+)-(RCLKIN-)

7.0 SIGNAL TIMING WAVEFORMS OF INTERFACE SIGNAL (DE MODE)

7.1 Vertical Timing Waveforms

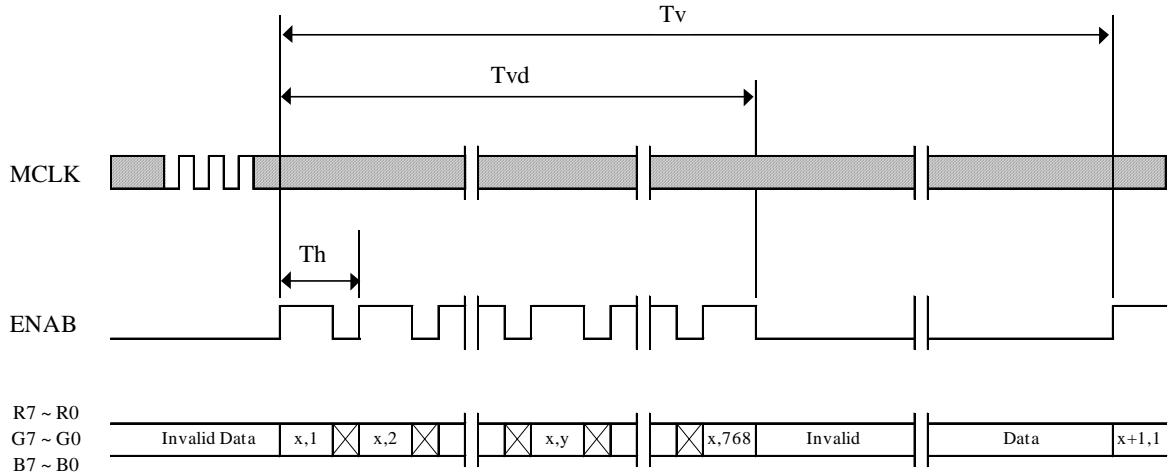

7.2 Horizontal Timing Waveforms

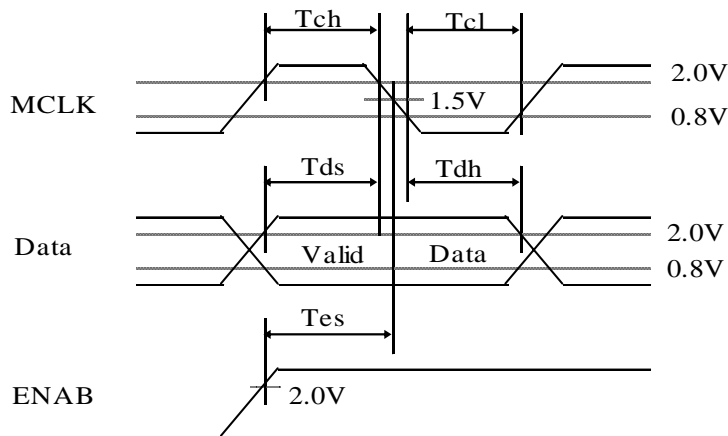
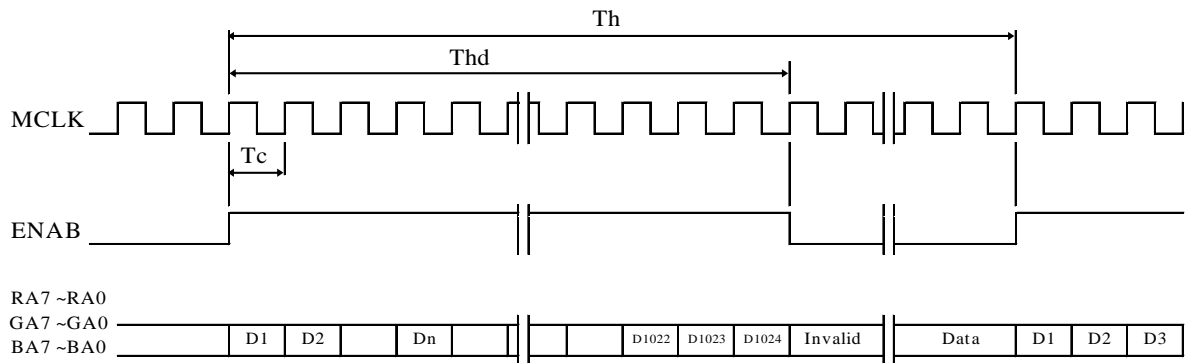



PRODUCT GROUP

REV

ISSUE DATE

TFT-LCD PRODUCT

P0

2008.11.28

8.0 INPUT SIGNALS, BASIC DISPLAY COLORS & GRAY SCALE OF COLORS

Colors & Gray Scale	Red Data						Green Data						Blue Data						
	R5	R4	R3	R2	R1	R0	G5	G4	G3	G2	G1	G0	B5	B4	B3	B2	B1	B0	
Basic Colors	Black	0	0	0	0	0	0	0	0	0	0	0	0	0	0	0	0	0	
	Blue	0	0	0	0	0	0	0	0	0	0	0	1	1	1	1	1	1	
	Green	0	0	0	0	0	0	1	1	1	1	1	1	0	0	0	0	0	
	Cyan	0	0	0	0	0	0	1	1	1	1	1	1	1	1	1	1	1	
	Red	1	1	1	1	1	1	0	0	0	0	0	0	0	0	0	0	0	
	Magenta	1	1	1	1	1	1	0	0	0	0	0	0	1	1	1	1	1	
	Yellow	1	1	1	1	1	1	1	1	1	1	1	1	0	0	0	0	0	
	White	1	1	1	1	1	1	1	1	1	1	1	1	1	1	1	1	1	
Gray Scale Of Red	Black	0	0	0	0	0	0	0	0	0	0	0	0	0	0	0	0	0	
	△	0	0	0	0	0	1	0	0	0	0	0	0	0	0	0	0	0	
	Darker	0	0	0	0	1	0	0	0	0	0	0	0	0	0	0	0	0	
	△	↓						↓						↓					
	▽	↓						↓						↓					
	Brighter	1	1	1	1	0	1	0	0	0	0	0	0	0	0	0	0	0	
	▽	1	1	1	1	1	0	0	0	0	0	0	0	0	0	0	0	0	
	Red	1	1	1	1	1	1	0	0	0	0	0	0	0	0	0	0	0	
Gray Scale Of Green	Black	0	0	0	0	0	0	0	0	0	0	0	0	0	0	0	0	0	
	△	0	0	0	0	0	0	0	0	0	0	0	1	0	0	0	0	0	
	Darker	0	0	0	0	0	0	0	0	0	0	1	0	0	0	0	0	0	
	△	↓						↓						↓					
	▽	↓						↓						↓					
	Brighter	0	0	0	0	0	0	1	1	1	1	0	1	0	0	0	0	0	
	▽	0	0	0	0	0	0	1	1	1	1	1	0	0	0	0	0	0	
	Green	0	0	0	0	0	0	1	1	1	1	1	1	0	0	0	0	0	
Gray Scale Of Blue	Black	0	0	0	0	0	0	0	0	0	0	0	0	0	0	0	0	0	
	△	0	0	0	0	0	0	0	0	0	0	0	0	0	0	0	0	1	
	Darker	0	0	0	0	0	0	0	0	0	0	0	0	0	0	0	0	1	
	△	↓						↓						↓					
	▽	↓						↓						↓					
	Brighter	0	0	0	0	0	0	0	0	0	0	0	0	1	1	1	1	0	1
	▽	0	0	0	0	0	0	0	0	0	0	0	0	1	1	1	1	1	0
	Blue	0	0	0	0	0	0	0	0	0	0	0	0	1	1	1	1	1	1
Gray Scale Of White & Black	Black	0	0	0	0	0	0	0	0	0	0	0	0	0	0	0	0	0	
	△	0	0	0	0	0	1	0	0	0	0	0	1	0	0	0	0	1	
	Darker	0	0	0	0	1	0	0	0	0	0	1	0	0	0	0	0	1	
	△	↓						↓						↓					
	▽	↓						↓						↓					
	Brighter	1	1	1	1	0	1	1	1	1	1	0	1	1	1	1	1	0	1
	▽	1	1	1	1	1	0	1	1	1	1	1	0	1	1	1	1	1	0
	White	1	1	1	1	1	1	1	1	1	1	1	1	1	1	1	1	1	1

SPEC. NUMBER

SPEC. TITLE

PAGE

HT121X01-101 Pre-Product Specification for NuAsia

15 / 26

9.0 POWER SEQUENCE

To prevent a latch-up or DC operation of the LCD module, the power on/off sequence shall be as shown in below

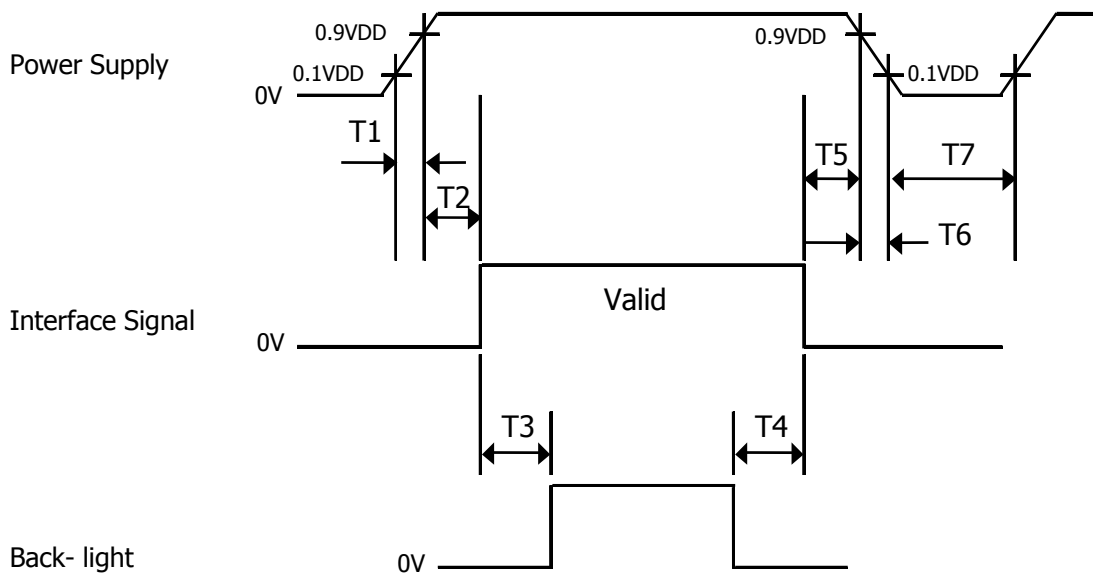

- $0 < T1 \leq 10 \text{ ms}$
- $0 < T2 \leq 50 \text{ ms}$
- $200 \text{ ms} \leq T3$
- $0 \text{ ms} \leq T4, 0 \text{ ms} \leq T5$
- $0 \leq T6 \leq 10 \text{ ms}$
- $150 \text{ ms} \leq T7$

Notes:

1. When the power supply VDD is 0V, Keep the level of input signals on the low or keep high impedance.
2. Do not keep the interface signal high impedance when power is on.
3. Back Light must be turn on after power for logic and interface signal are valid.

10.0 MECHANICAL CHARACTERISTICS

10.1 Dimensional Requirements

FIGURE 5, 6 shown in appendix shows mechanical outlines for the model.

Parameter	Specification	Unit
Active area	245.76 (H) × 184.32 (V)	mm
Number of pixels	1024(H) × 768(V)	pixels
	(1 pixel = R + G + B dots)	
Pixel pitch	0.240(H) × 0.240(V)	mm
Pixel arrangement	RGB Vertical stripe	
Display colors	262,144	colors
Display mode	Normally white	
Dimensional outline	261.0±0.4(W)×198.0±0.4(V)×4.7(D) Typ./5.0(D)Max.	mm
Weight	275 (Typ.) / 285 (Max.)	g
Back-light	CCFL, Horizontal-lamp type	

10.2 Mounting

See FIGURE 5. (shown in Appendix)

10.3 Anti-Glare and Polarizer Hardness.

The surface of the LCD has an anti-glare coating to minimize reflection and a coating to reduce scratching. (LGC : HC-LR / 2H)

10.4 Light Leakage

There shall not be visible light from the back-lighting system around the edges of the screen as seen from a distance 50 cm from the screen with an overhead light level of 150lux. The manufacture shall furnish limit samples of the panel showing the light leakage acceptable.

**11.0 RELIABILITY TEST**

No	Test Items	Conditions
1	High temperature storage test	Ta = 60 °C, 240 hrs
2	Low temperature storage test	Ta = -20 °C, 240 hrs
3	High temperature & high humidity operation test	Ta = 50 °C, 80~85%RH, 1000hrs
4	Life Test	Ta = 25 °C, 1000 hrs
5	High temperature operation test	Ta = 50 °C, 240 hrs
6	Low temperature operation test	Ta = 0 °C, 240 hrs
7	On/Off test	Ta = 25 °C, 1min, On/Off 30000 cycle
8	Thermal shock	Ta = -20 °C ↔ 60 °C (30 min), 100 cycle
9	Vibration test (non-operating)	1.5G, 10~200Hz for X,Y,Z axis 30min for each axis
10	Shock test (non-operating)	210G, 3msec, half sine for X,Y,Z axis 50G, 18msec, trapezoidal for X,Y,Z axis
11	Altitude Test	53.3 Kpa (altitude 5000m), 24hrs
12	Open/Short Test	DS158, Open/Short Test Plan
13	Electro-Static Discharge Test (non-operating)	Air : 150pF, 330ohm, 15KV Contact : 150pF, 330ohm, 8KV

* Note : The bezel of HT121X01 is Aluminum (AL 5052 H34).

 HYDIS	PRODUCT GROUP	REV	ISSUE DATE
	TFT-LCD PRODUCT	P0	2008.11.28

12.0 HANDLING & CAUTIONS

12.1 Cautions when taking out the module

- Pick the pouch only, when taking out module from a shipping package.

12.2 Cautions for handling the module

- As the electrostatic discharges may break the LCD module, handle the LCD module with care. Peel a protection sheet off from the LCD panel surface as slowly as possible.
- As the LCD panel and backlight element are made from fragile glass material, impulse and pressure to the LCD module should be avoided.
- As the surface of the polarizer is very soft and easily scratched, use a soft dry cloth without chemicals for cleaning.
- Do not pull the interface connector in or out while the LCD module is operating.
- Put the module display side down on a flat horizontal plane.
- Handle connectors and cables with care.

12.3 Cautions for the operation

- When the module is operating, do not lose MCLK, DE signals. If any one of these signals were lost, the LCD panel would be damaged.
- Obey the supply voltage sequence. If wrong sequence were applied, the module would be damaged.

12.4 Cautions for the atmosphere

- Dewdrop atmosphere should be avoided.
- Do not store and/or operate the LCD module in a high temperature and/or humidity atmosphere. Storage in an electro-conductive polymer-packing pouch and under relatively low temperature atmosphere is recommended.

12.5 Cautions for the module characteristics

- Do not apply fixed pattern data signal to the LCD module at product aging.
- Applying fixed pattern for a long time may cause image sticking.

12.6 Other cautions

- Do not disassemble and/or re-assemble LCD module.
- Do not re-adjust variable resistor or switch etc.
- When returning the module for repair or etc, please pack the module not to be broken. We recommend using the original shipping packages.

SPEC. NUMBER	SPEC. TITLE	PAGE
B2005-C001-C(3/3)	HT121X01-101 Pre-Product Specification for NuAsia	19 / 26

B2005-C001-C(3/3)

A4(210 X 297)

13.0 PACKING

13.1 Packing Order

Put Pad into the box.

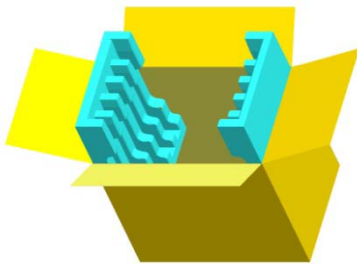

Put silica gels in the box.

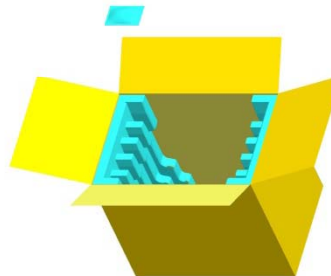

After sealing the box, attach Packing Label on the attach position sign area of the box.

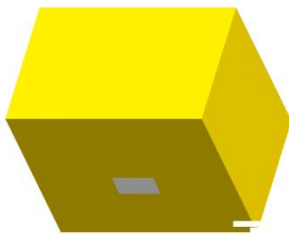

Place a cover on the top of the box.

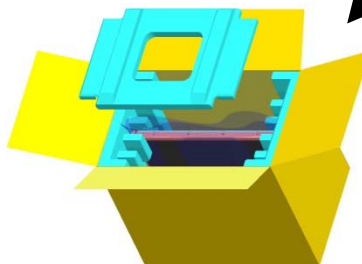

As shown in the figure, place the Modules bundled by shielding bag in the box.

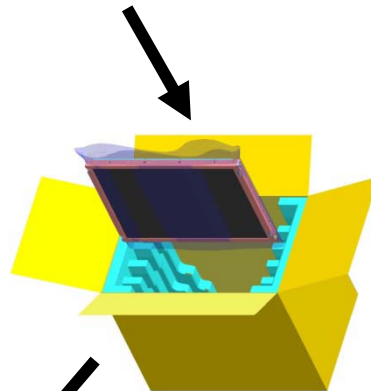

Notes

Box Dimension: 349mm(W)X 261mm(D)X 311(H)
 Package Quantity in one Box: 10pcs



PRODUCT GROUP

REV

ISSUE DATE

TFT-LCD PRODUCT

P0

2008.11.28

14.0 Environment & Safety

14.1 Packing Label

Label Size: 108 mm (L) × 56 mm (W)

Contents

Model: HT121X01-101

Q`ty: Module Q`ty in one box

Serial No.: Box Serial No. See next figure for detail description.

Date: Packing Date

FG Code: FG Code of Product

T.B.D

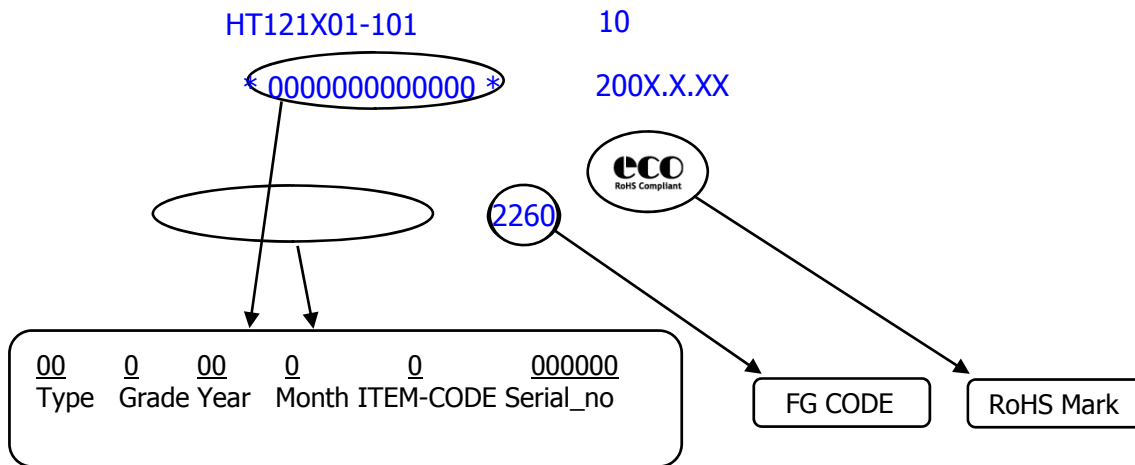

14.2 Mercury disposal & High voltage caution

	HIGH VOLTAGE CAUTION	COLD CATHODE FLUORESCENT LAMP IN LCD PANEL CONTAINS A SMALL AMOUNT OF MERCURY. PLEASE FOLLOW LOCAL ORDINANCES OR REGULATIONS FOR DISPOSAL.
	RISK OF ELECTRIC SHOCK, DISCONNECT THE ELECTRIC POWER BEFORE SERVICING	

SPEC. NUMBER

SPEC. TITLE
HT121X01-101 Pre-Product Specification for NuAsia

PAGE
21 / 26



PRODUCT GROUP

REV

ISSUE DATE

TFT-LCD PRODUCT

P0

2008.11.28

14.3 Product Label

T.B.D

BOE HYDIS Barcode

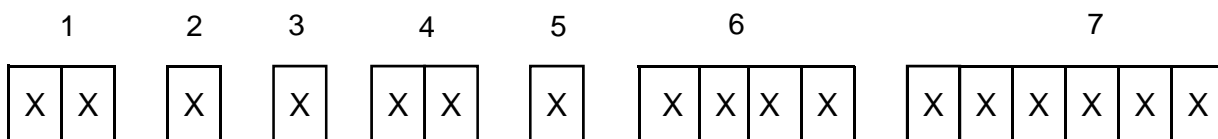

No 1. Control Number

No 5. Month (1, 2, 3,..., 9, X, Y, Z)

No 2. Rank / Grade

No 6. FG Code

No 3. Line Classification
(BOE HYDIS : H, LCM : L, BOE OT : A/B/C)

No 7. Serial Number

No 4. Year (5 : 2005, 6 : 2006, ...)

SPEC. NUMBER

SPEC. TITLE
HT121X01-101 Pre-Product Specification for NuAsia

PAGE
22 / 26

B2005-C001-C(3/3)

A4(210 X 297)

15.0 APPENDIX

Figure 1. Measurement Set Up

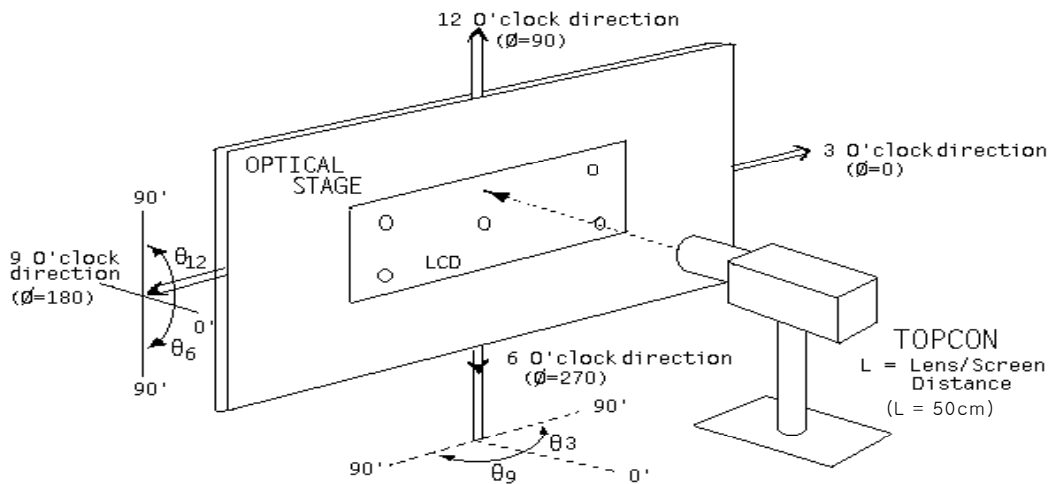

Figure 2. Average Luminance Measurement Locations & Uniformity Measurement Locations

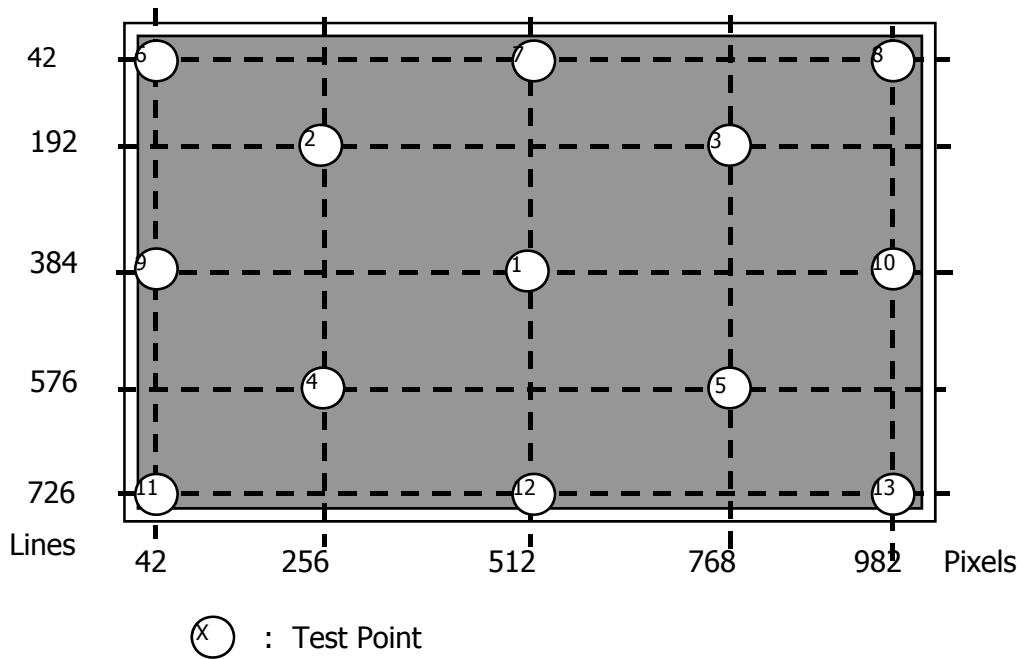
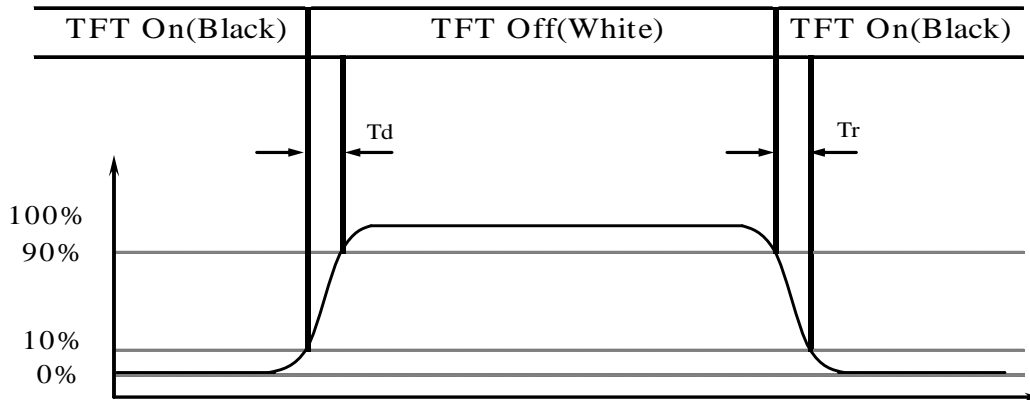
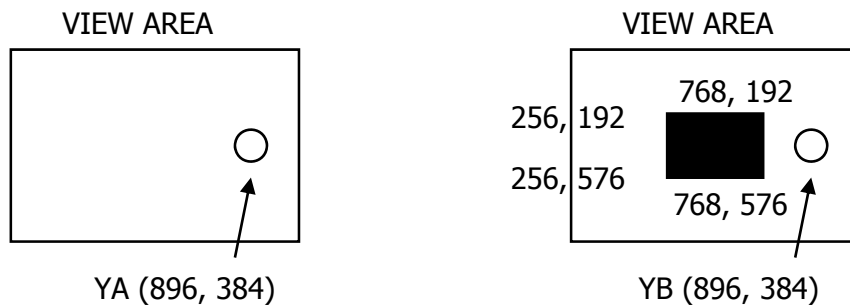

Figure 3. Response Time Testing

Figure 4. Cross Modulation Test Description

$$\text{Cross-Talk} = \left| \frac{Y_B - Y_A}{Y_A} \right| \times 100$$

Where:

Y_A = Initial luminance of measured area (cd/m²)

Y_B = Subsequent luminance of measured area (cd/m²)

The location measured will be exactly the same in both patterns.

Figure 5. TFT-LCD Module Outline Dimensions (Front view)

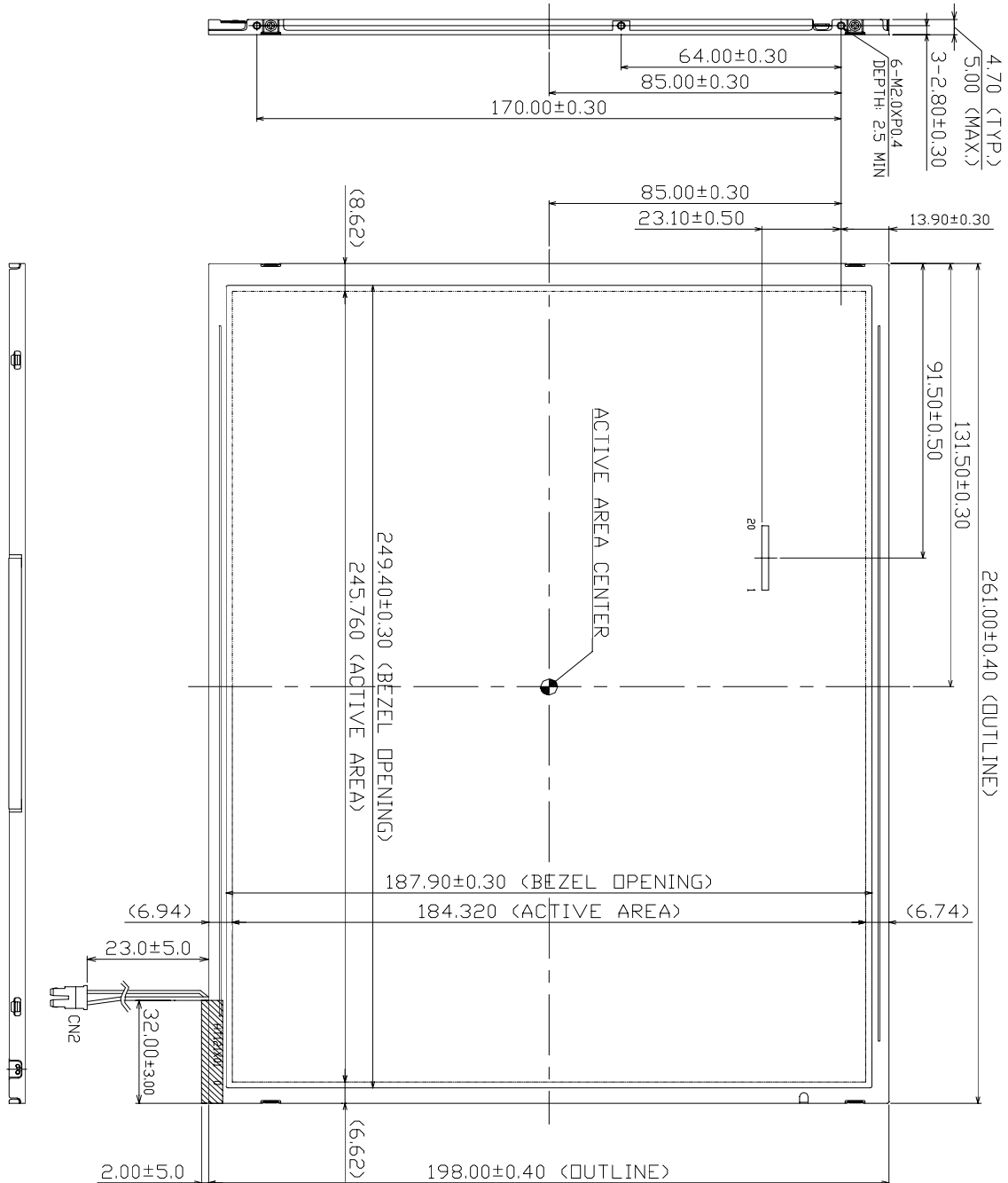
SPEC. NUMBER
SPEC. TITLE
 HT121X01-101 Pre-Product Specification for NuAsia

PAGE
 25 / 26

Figure 6. TFT-LCD Module Outline Dimensions (Rear view)

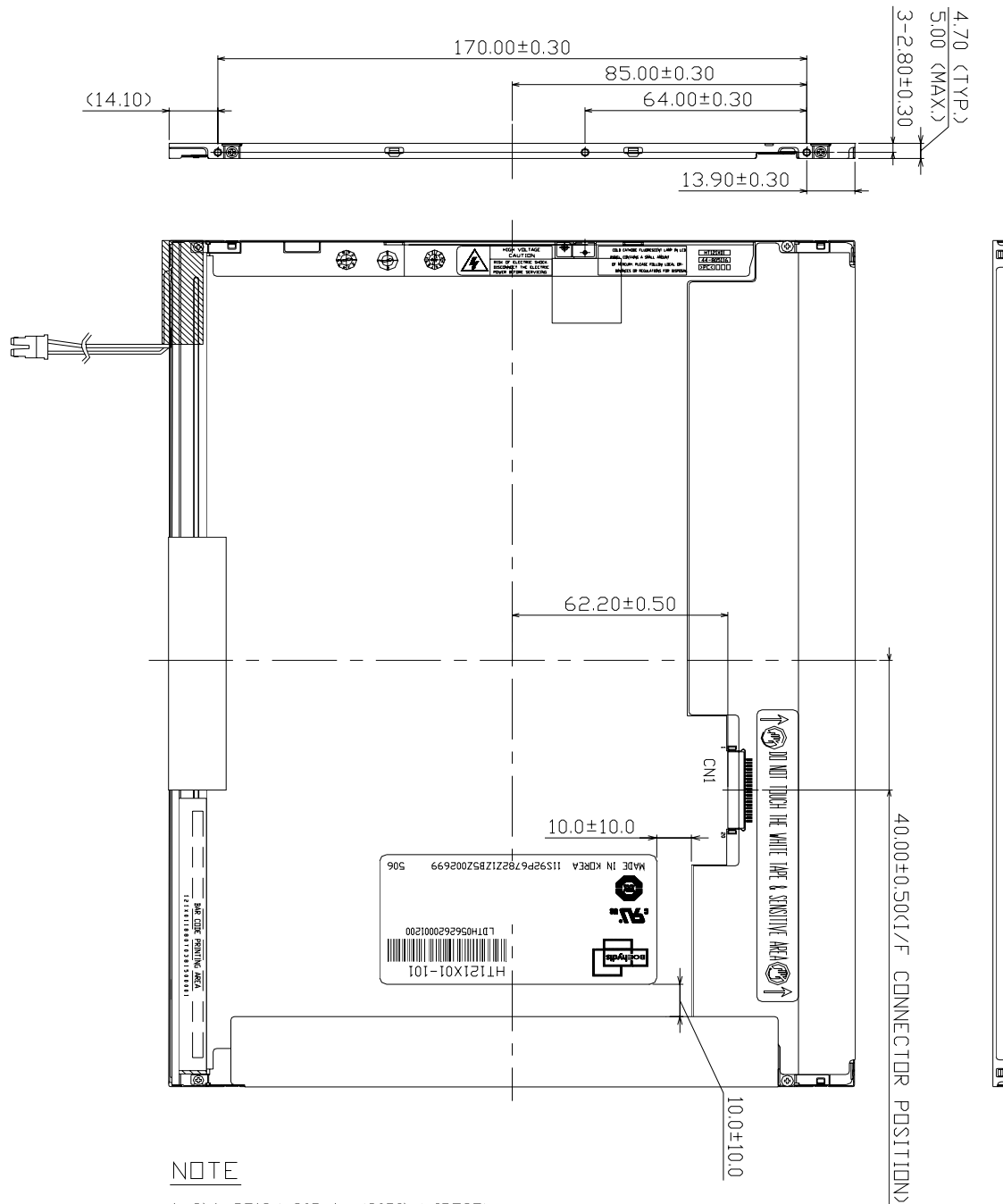

NOTE

1. CN1: DF19K-20P-1H (20PIN/HIROSE)
2. CN2: BHSR-02VS-1 (2PIN/JST)
3. SCREW TORQUE : 2.3Kgf-cm
4. GENERAL TOLERANCE: ±0.50

SPEC. NUMBER

SPEC. TITLE

HT121X01-101 Pre-Product Specification for NuAsia

PAGE

26 / 26