



Chunghwa Picture Tubes, Ltd.

Product Specification

To : Studio Technology Co.,Ltd
Date : 2009/09/28

TFT LCD
CLAA133WA01A

Accepted by:

APPROVED BY	CHECKED BY	PREPARED BY
Ronald Huang	Roger Liu	Carol Shen

Prepared by :
Product Planning Management Division
Notebook Business Unit
CHUNGHWA PICTURE TUBES, LTD.

1127 Hopin Rd., Padeh, Taoyuan, Taiwan 334, R.O.C.
TEL: +886-3-3675151 FAX: +886-3-377-3003

Doc.No:	CLAA133WA01A-S.C.L-T1-20090928	Issue Date:	2009/09/28
---------	--------------------------------	-------------	------------

CONTENTS

1. OVERVIEW.....	4
2. ABSOLUTE MAXIMUN RATINGS.....	5
3. ELECTRICAL CHARACTERISTICS.....	6
4. CONNECTER INTERFACE PIN & DUNCTION.....	10
5. INTERFACE TIMING CHART.....	11
6. BLOCK DUAGRAM.....	13
7. MECHANICAL DIMENSION.....	14
8. OPTICAL CHARACTERISTICS.....	16
9. RELIABILITY TEST CONDITIONS.....	20

Studio Technology Co., Ltd

1. OVERVIEW

CLAA133WA01A is 13.3" color TFT-LCD (Thin Film Transistor Liquid Crystal Display) module composed of LCD panel, LVDS driver ICs, control circuit and LED backlight. By applying 6 bit digital data, 1366×RGB(3)×768, 262K colors are displayed on the 13.3" diagonal screen.

General specification are summarized in the following table:

ITEM	SPECIFICATION
Display Area (mm)	293.417(H) x 164.966(V) (13.3-inch diagonal)
Number of Pixels	1366(H) × 3(RGB) × 768(V)
Pixel Pitch (mm)	0.2148 (H) × 0.2148 (V)
Color Pixel Arrangement	RGB vertical stripe
Display Mode	Normally white
Number of Colors	262,144
Gamut	42% (min) / 45% (typ)
Optimum Viewing Angle	6 o'clock
Response Time (Tr+Tf)	8ms (typ)
Surface Treatment	Glare type Hardness:3H
Viewing Angle(BL on,CR≥10)	40/40/15/30 degree (min)
Brightness (cd/m ²)	200nit (typ) / 16mA
Uniformity	5point : 80 %(Min) 13point : 65 %(Min)
Power Consumption	3.6 W (max)
Module Size (mm)	314.6(W)×189.25(H)×3.6(D) (Max)
Module Weight (g)	290(max)

The LCD Products listed on this document are not suitable for use of aerospace equipment, submarine cable, and nuclear reactor control system and life support systems. If customers intend to use these LCD products for applications listed above or those not included in the "Standard" list as follows, please contact our sales in advance.

Standard : Computer, Office equipment, Communication equipment, Test and Measurement equipment, Machine tool, Industrial robot, Audio and Visual equipment, Other consumer products.

2. ABSOLUTE MAXIMUM RATINGS

The following are maximum values, which if exceeded, may cause faulty operation or damage to the unit.

ITEM	SYMBOL	MIN.	MAX.	UNIT	REMARK
Power Supply Voltage for LCD	VCC	0	4.0	V	
LED Driver Input Voltage	VBL+	0	22	V	
LED Driver Input Current	IBL+	-	(650)	mA	*8)
PWM Frequency	PWM_BL	180	1000	MHz	*7)
Duty ratio	Dim	10	100	%	
LED Forward Current	I _F	-	25	mA	*1).2)
Operation Temperature	Top	(0)	(50)	°C	*3). 4). 5). 6)
Storage Temperature	Tstg	(-25)	(65)	°C	*3). 4). 5)

【Note】

- *1) Product life-time relate to LED current, please operate production follow statement at page 9 “(B)Backlight”.
- *2) When LED current over the definition of absolute max, product life-time will decay rapidly or operate unusual.
- *3) The relative temperature and humidity range are as below sketch, 90%RH Max. (Ta ≤ 40°C)
- *4) The maximum wet bulb temperature ≤ 39°C (Ta > 40°C) and without dewing.
- *5) If product in environment which over the definition of the relative temperature and humidity out of range too long, it will affect visual of LCD.
- *6) If you operate LCD in normal temperature range, the center surface of panel should be under 50°C.
- *7) The suggested external PWM frequency's typical value is 200Hz.
- *8) Maximum LED Driver Input Current at 7V Input Voltage.

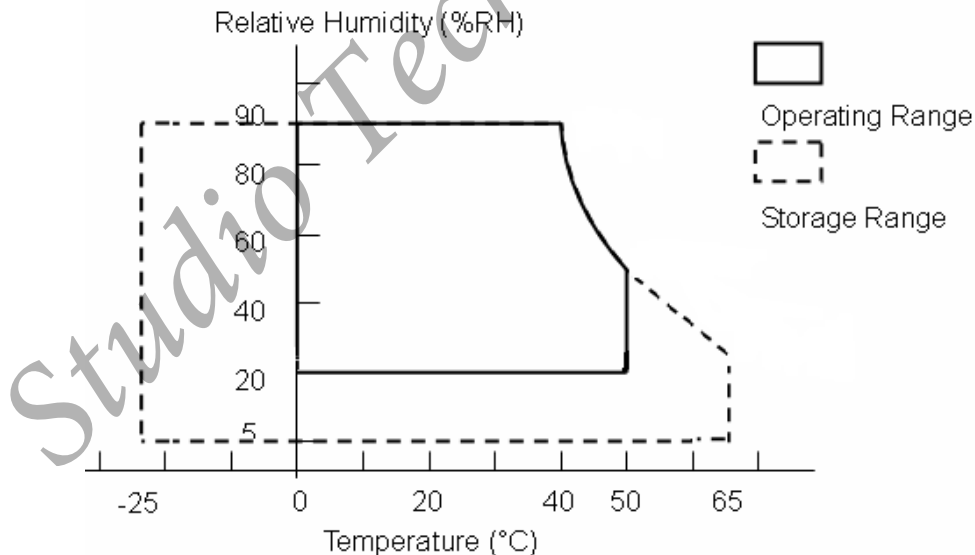

3. ELECTRICAL CHARACTERISTICS

(A) TFT LCD Power Voltage

TEM	SYMBOL	MIN	TYP	MAX	UNIT	REMARK	
LCD POWER VOLTAGE	VCC	3.0	3.3	3.6	V	【Note 1】	
LCD POWER CURRENT	ICC	-	(400)	(500)	mA	【Note 2】	
Rush CRRENT	Irush	-	-	2	A	【Note 4】	
LOGIC INPUT VOLTAGE (LVDS: IN+,IN-)	INPUT VOLTAGE	VIN	0	-	VCC	【Note 3】	
	COMMON VOLTAGE	VCM	1.125	1.25	1.375	V	【Note 3】
	DIFFRENTIAL INPUT VOLTAGE	VID	250	350	450	mV	【Note 3】
	THRESHOLD VOLTAGE (HIGH)	VTH	-	-	100	mV	【Note 3】
	THRESHOLD VOLTAGE (LOW)	VTL	-100	-	-	mV	When VCM = +1.2V

【Note 1】 Power Sequence :

- $0.5\text{ ms} \leq t1 \leq 10\text{ms}$
- $0.01\text{ ms} < t2 \leq 50\text{ ms}$
- $0.01\text{ ms} < t3 \leq 50\text{ ms}$
- $500\text{ms} \leq t4$
- $200\text{ ms} \leq t5$
- $200\text{ ms} \leq t6$

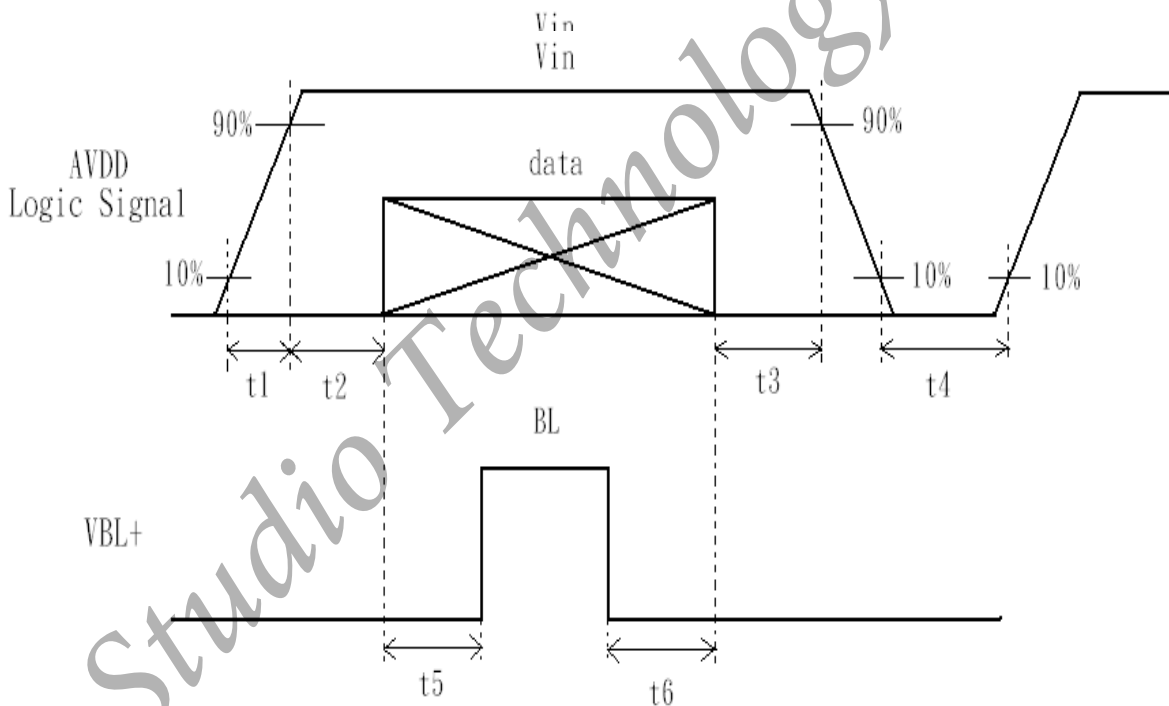

data: RGB DATA, DCLK, HD, VD, DENA

VCC-dip state

(1) when $3.0 > VCC \geq 2.7V$ & $td \leq 10$ ms module works well.

(2) when $VCC < 2.7V$, VCC-dip condition should be the same as the VCC-turn-off condition.

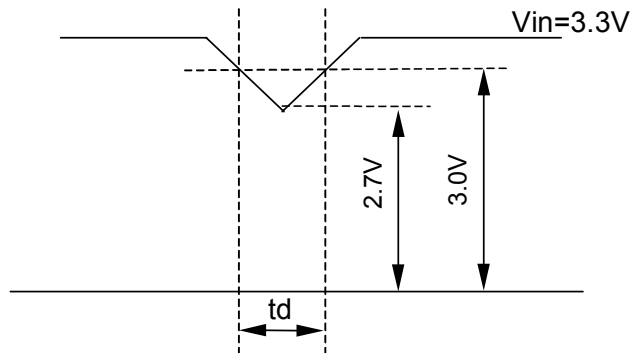

【Note 2】 Typical value is Mosaic (32*36 Checker board) Pattern : 768 line mode ◦

Circuit condition (typ) : $VCC=3.3$ V , $fV=60$ Hz $fH=48.36$ kHz , $fCLK=75.44$ MHz

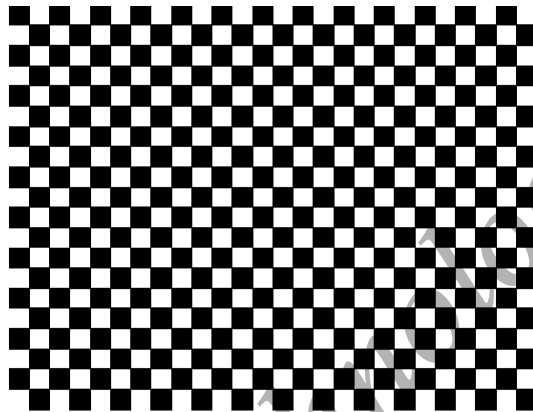

Max value is Black Pattern : 768 line mode ◦

Circuit condition (max) : $VCC=3.3$ V , $fV=60$ Hz $fH=48.36$ kHz , $fCLK=75.44$ MHz

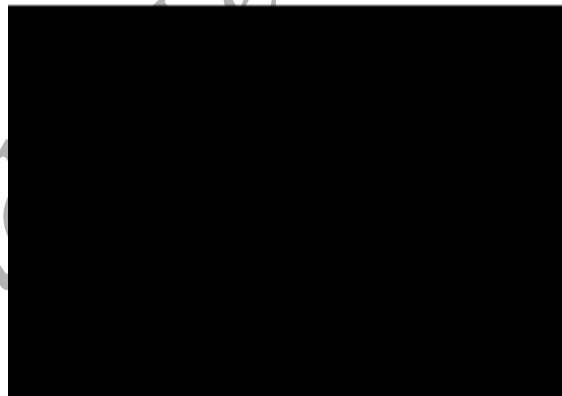

【Note 3】 LVDS Signal Definite :

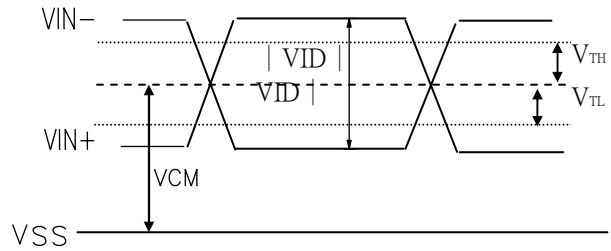
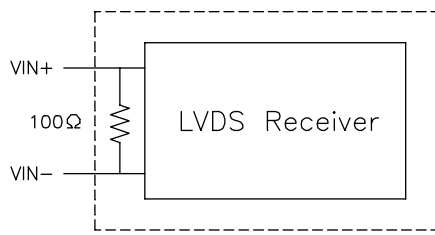

VIN+ : Positive differential DATA & CLK Input
 VIN- : Negative differential DATA & CLK Input

【Note 4】 Irush measure condition

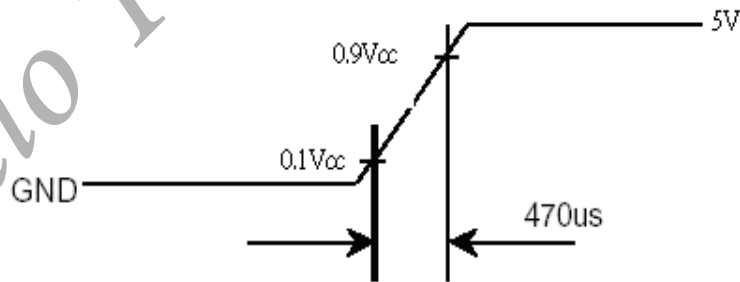
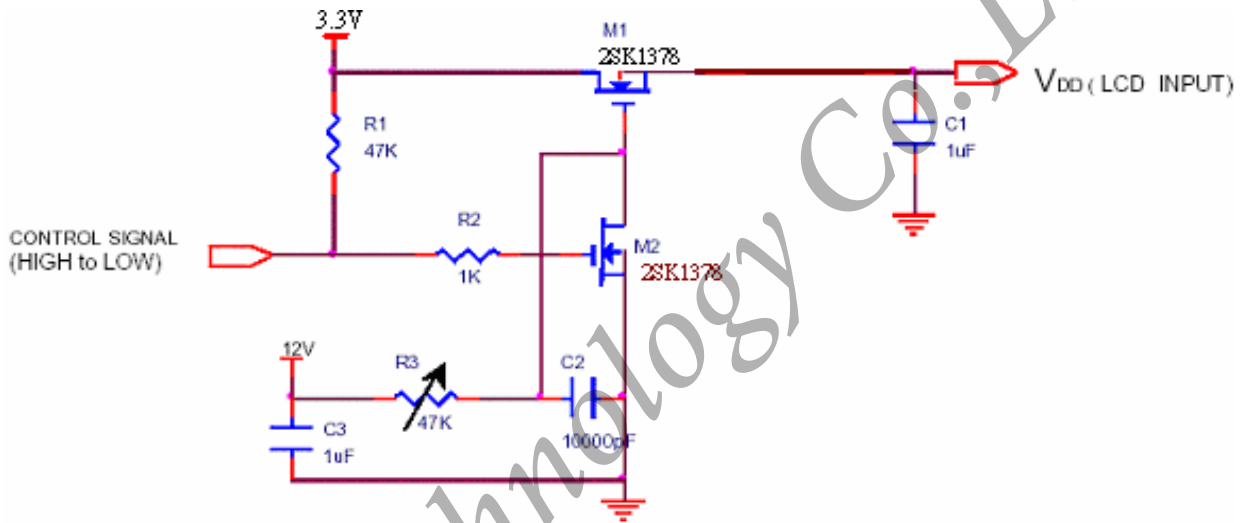

(B) BACKLIGHT

(a) Electrical Characteristics

Ta=25°C

ITEM	SYMBOL	MIN	TYP	MAX	UNIT	NOTE
Forward Voltage	V _F	2.9	3.2	3.5	V	
Forward Current	I _F	15.5	16	16.5	mA	
BL Power consumption	W	2.18	2.41	2.64	W	*1) I _F =16mA

Note:BL power consumption $P = n \times (V_F \times I_F) \div \text{driver efficiency}$
n: number of LED

(b) LED Life Time

ITEM	Condition	min	typ	max	UNIT	NOTE
LIFE TIME	I _F =20mA · Ta=25°C	15000	-	-	hrs	*2)

【Note】

*1) Measure method :

- LED current is measured by utilizing a current meter as show below.
- We set up system power input voltage at 12V to measurement PLED.

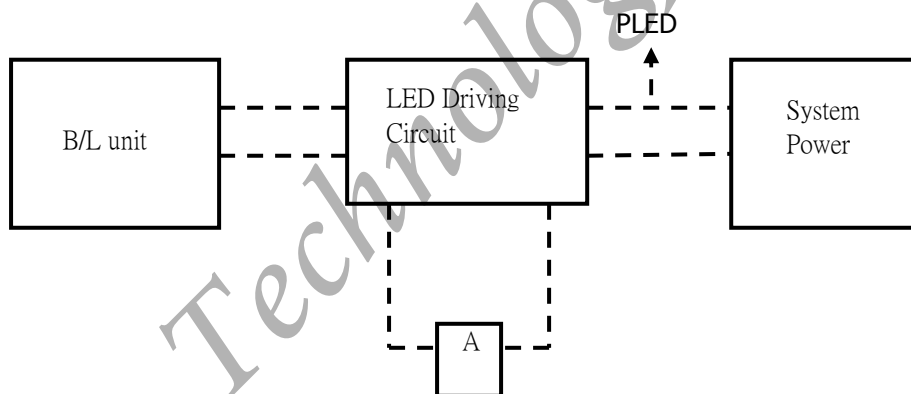

*2) Lifetime means that estimated time to 50% degradation of initial luminous intensity.

4. CONNECTOR INTERFACE PIN & FUNCTION

CN (Interface signal)

Outlet connector: I-PEX 20455-040E-12

Pin No.	SYMBOL	FUNCTION
1	DIAG_LOOP	Diag pin for Dell testing. Pin 1 & 34 must be connected together on the inverter board
2	VDD	Power Supply, 3.3 V (typical)
3	VDD	Power Supply, 3.3 V (typical)
4	V EEDID	DDC 3.3V power
5	NC	No connection
6	Clk EEDID	DDC Clock
7	DATA EEDID	DDC Data
8	Odd_Rin0-	- LVDS differential data input (R0-R5, G0) (odd pixels)
9	Odd_Rin0+	+ LVDS differential data input (R0-R5, G0) (odd pixels)
10	VSS	Ground – Shield
11	Odd_Rin1-	- LVDS differential data input (G1-G5, B0-B1) (odd pixels)
12	Odd_Rin1+	+ LVDS differential data input (G1-G5, B0-B1) (odd pixels)
13	VSS	Ground – Shield
14	Odd_Rin2-	- LVDS differential data input (B2-B5, HS, VS, DE) (odd pixels)
15	Odd_Rin2+	+ LVDS differential data input (B2-B5, HS, VS, DE) (odd pixels)
16	VSS	Ground – Shield
17	Odd_ClkIN-	- LVDS differential clock input (odd pixels)
18	Odd_ClkIN+	+ LVDS differential clock input (odd pixels)
19	VSS	Ground – Shield
20	NC	No connection
21	NC	No connection
22	VSS	Ground – Shield
23	NC	No connection
24	NC	No connection
25	VSS	Ground – Shield
26	NC	No connection
27	NC	No connection
28	VSS	Ground – Shield
29	NC	No connection
30	NC	No connection
31	VSSLED	Ground – LED
32	VSSLED	Ground – LED
33	VSSLED	Ground – LED
34	DIAG_LOOP	Diag pin for Dell testing. Pin 1 & 34 must be connected together on the inverter board
35	PWM	System PWM Signal Input (+3.3V Swing)
36	LED_EN	LED enable pin (+3.3V Input)
37	NC	NC
38	VDDLED	7 V – 21V LED power
39	VDDLED	7V – 21V LED power
40	VDDLED	7V – 21V LED power

5. INTERFACE TIMING CHART

(A) LVDS input time sequence

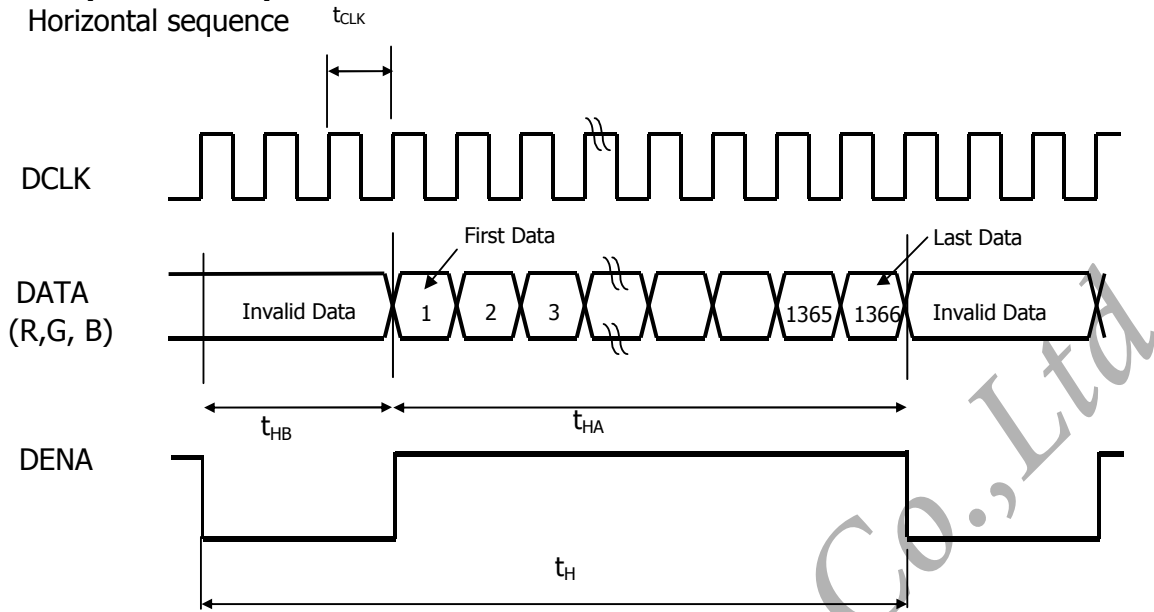

(B) LCD input time sequence

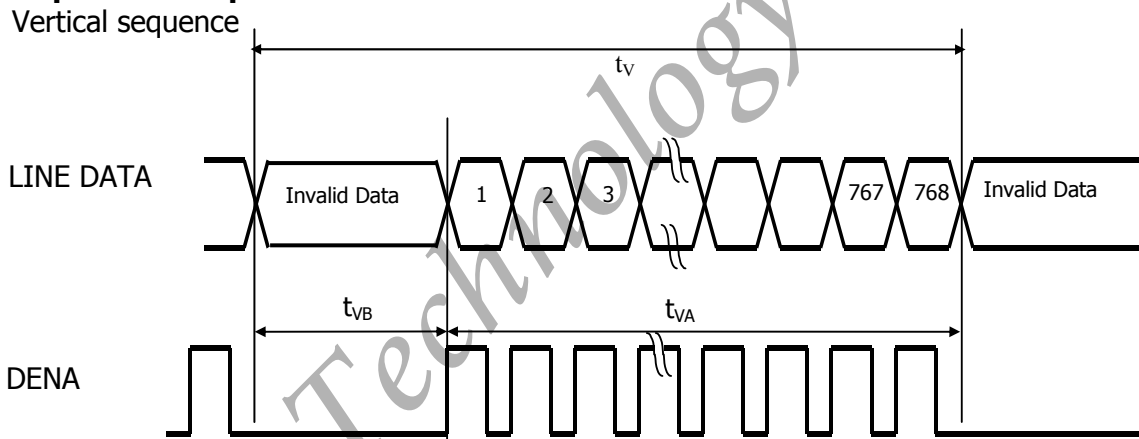

(C) Timing Chart

ITEM		SYMBOL	MIN	TYP	MAX	UNIT		
LCD Timing	Frame Rate	-	60			Hz		
	DCLK	Frequency	f_{CLK}	65.83	75.44	88.74	MHz	
		Period	t_{CLK}	11.26	13.25	15.19	ns	
	DENA	Horizontal	Horizontal total time	t_H	1414	1560	1700	t_{CLK}
			Horizontal Active time	t_{HA}	1366	1366	1366	t_{CLK}
			Horizontal Blank time	t_{HB}	48	194	334	t_{CLK}
	Vertical	Vertical total time	t_v	776	806	870	t_H	
		Vertical Active time	t_{vA}	768	768	768	t_H	
Vertical Blank time		t_{vB}	8	38	114	t_H		

【Note】

- *1) DENA (DATA ENABLE) usually is positive.
- *2) During the whole blank period, DCLK should keep input.

(D) DATA mapping

Color	Input Data	R DATA						G DATA						B DATA					
		R5	R4	R3	R2	R1	R0	G5	G4	G3	G2	G1	G0	B5	B4	B3	B2	B1	B0
		MS B					LSB	MS B					LSB	MS B					LSB
Basic Color	Black	0	0	0	0	0	0	0	0	0	0	0	0	0	0	0	0	0	0
	Red(63)	1	1	1	1	1	1	0	0	0	0	0	0	0	0	0	0	0	0
	Green(63)	0	0	0	0	0	0	1	1	1	1	1	1	0	0	0	0	0	0
	Blue(63)	0	0	0	0	0	0	0	0	0	0	0	0	1	1	1	1	1	1
	Cyan	0	0	0	0	0	0	1	1	1	1	1	1	1	1	1	1	1	1
	Magenta	1	1	1	1	1	1	0	0	0	0	0	0	1	1	1	1	1	1
	Yellow	1	1	1	1	1	1	1	1	1	1	1	1	0	0	0	0	0	0
	White	1	1	1	1	1	1	1	1	1	1	1	1	1	1	1	1	1	1
RED	RED(0)	0	0	0	0	0	0	0	0	0	0	0	0	0	0	0	0	0	0
	RED(1)	0	0	0	0	0	1	0	0	0	0	0	0	0	0	0	0	0	0
	RED(2)	0	0	0	0	1	0	0	0	0	0	0	0	0	0	0	0	0	0
	RED(62)	1	1	1	1	1	0	0	0	0	0	0	0	0	0	0	0	0	0
	RED(63)	1	1	1	1	1	1	0	0	0	0	0	0	0	0	0	0	0	0
	Green	Green(0)	0	0	0	0	0	0	0	0	0	0	0	0	0	0	0	0	0
Green(1)		0	0	0	0	0	0	0	0	0	0	0	1	0	0	0	0	0	0
Green(2)		0	0	0	0	0	0	0	0	0	0	1	0	0	0	0	0	0	0
Green(62)		0	0	0	0	0	0	1	1	1	1	1	0	0	0	0	0	0	0
Green(63)		0	0	0	0	0	0	1	1	1	1	1	1	0	0	0	0	0	0
Blue		Blue(0)	0	0	0	0	0	0	0	0	0	0	0	0	0	0	0	0	0
	Blue(1)	0	0	0	0	0	0	0	0	0	0	0	0	0	0	0	0	0	1
	Blue(2)	0	0	0	0	0	0	0	0	0	0	0	0	0	0	0	0	1	0
	Blue(62)	0	0	0	0	0	0	0	0	0	0	0	0	1	1	1	1	1	0
	Blue(63)	0	0	0	0	0	0	0	0	0	0	0	0	1	1	1	1	1	1

【Note】

- 1) Gray level :
Color(n) : n is level order; higher n means brighter level.
- 2) DATA :
1; high , 0: low

6. BLOCK DIAGRAM

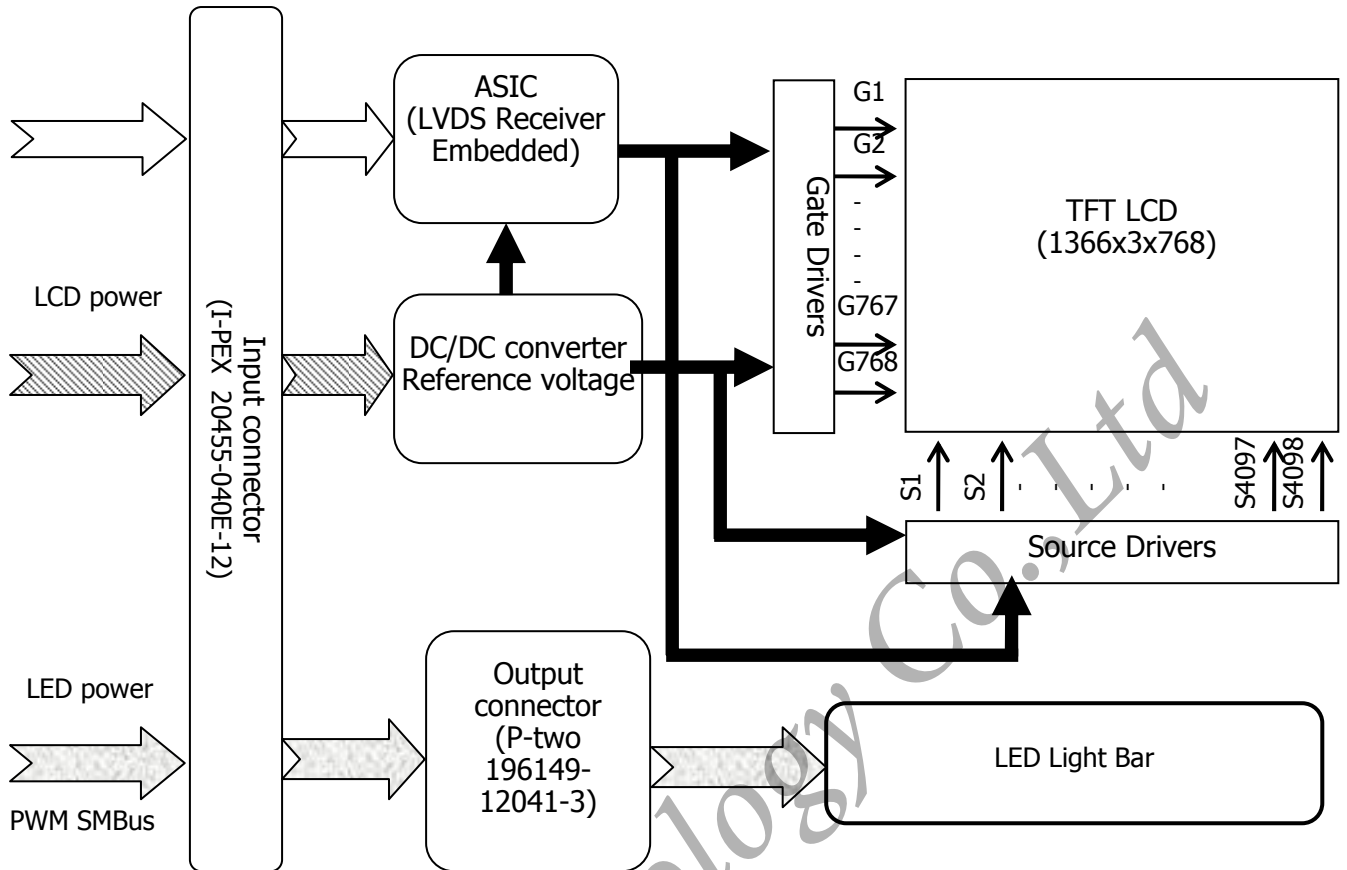

Studio Technology Co., Ltd

7. MECHANICAL SPECIFICATION

(A)Front side

The tolerance, not show in the figure, is $\pm 0.5\text{mm}$.

[Unit : mm]

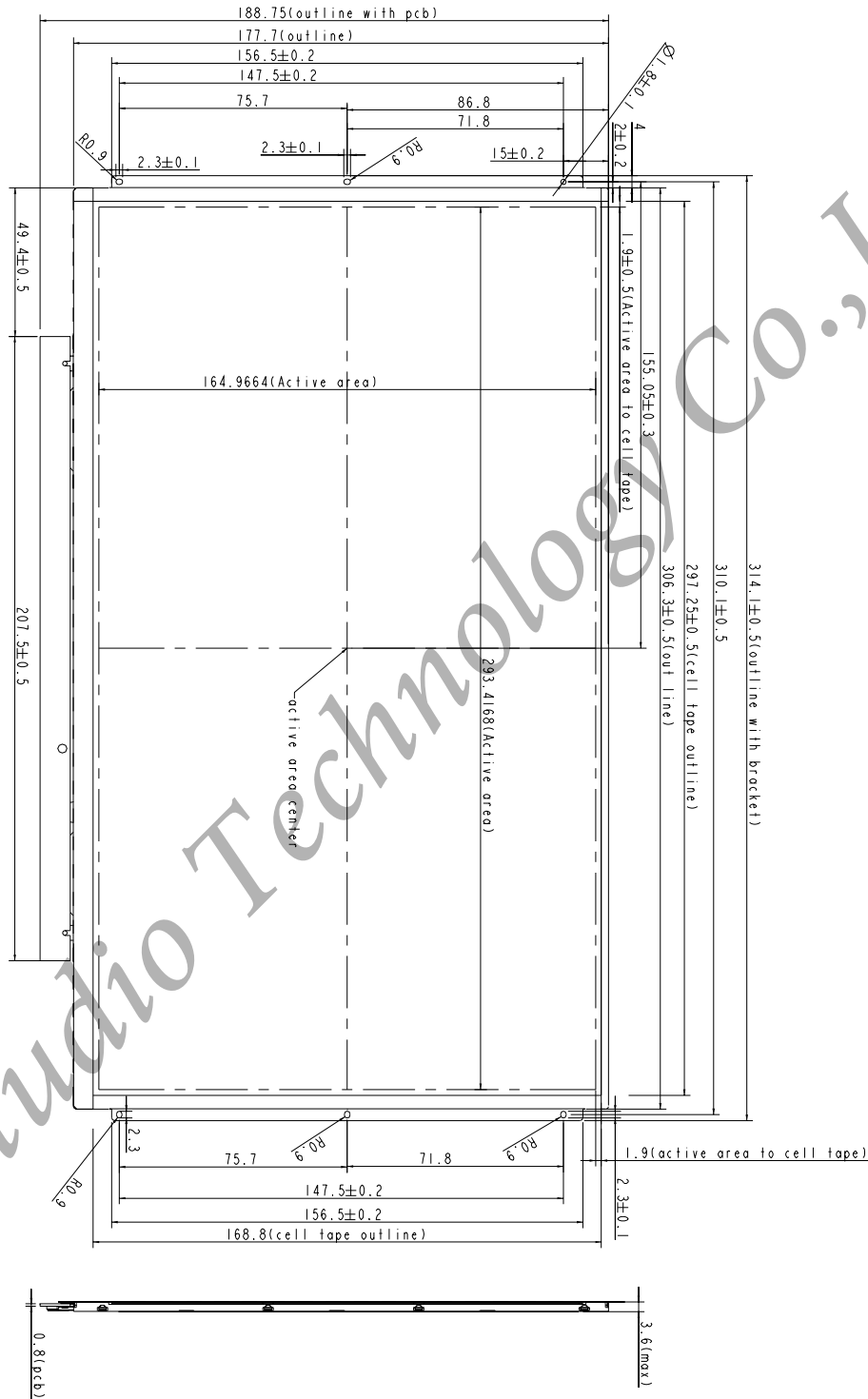

(B) Rear side

The tolerance, not show in the figure, is $\pm 0.5\text{mm}$.

[Unit : mm]

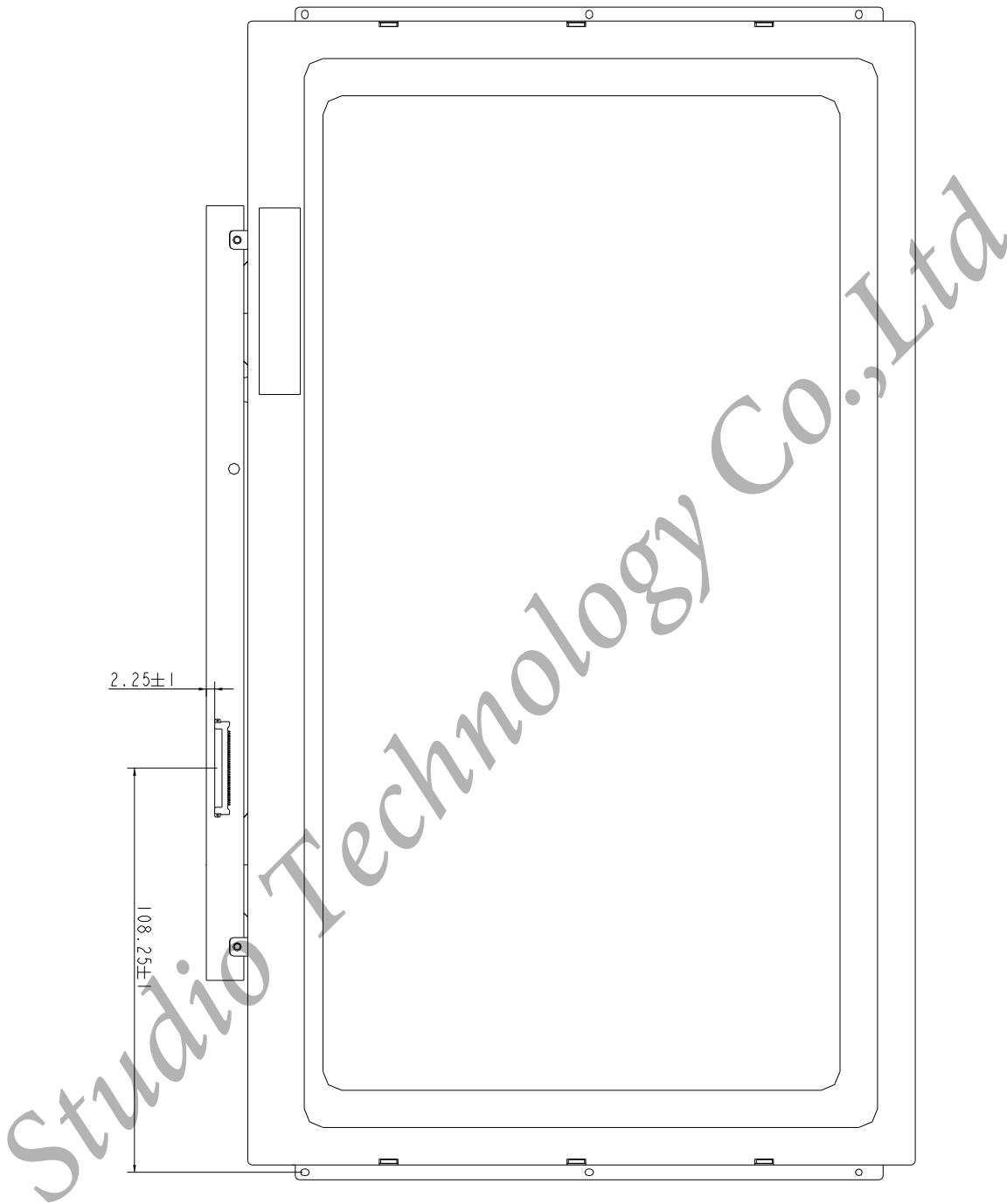

8. OPTICAL CHARACTERISTICS

Ta=25°C · VDD=3.3V

ITEM		SYMBOL	CONDITION	MIN.	TYP.	MAX.	UNIT	NOTE
Contrast Ratio		CR	Point-7	500	600	-	--	*1) 2)
Luminance (5P)		L	5-Point Avg.	180	200	-	cd/m ²	*1) 3)
Uniformity(5P)		ΔL	θ = ψ = 0°	80	-	-	%	*1) 3)
Response Time		Tr	θ = ψ = 0°	-	8	16	ms	*5)
Cross talk		CT	θ = ψ = 0°	-	-	1	%	*6)
View angle	Horizontal	ψ	CR ≥ 10	40/-40	-	-	°	*4)
	Vertical	θ		15/-30	-	-	°	*4)
Color Temperature Coordinate	W	X	θ = ψ = 0°	0.293	0.313	0.333	--	*3)
		Y		0.309	0.329	0.349		
	R	X		TBD	TBD	TBD	--	
		Y		TBD	TBD	TBD		
	G	X		TBD	TBD	TBD	--	
		Y		TBD	TBD	TBD		
	B	X		TBD	TBD	TBD	--	
Y		TBD	TBD	TBD				
Gamut			θ = ψ = 0°	42%	45%	-	--	-
Gamma		γ	GL	2.0	2.2	2.4	--	*7)

Color coordinate and color gamut are measured by SRUL1R, response time is measured by TRD-100, and all the other items are measured by BM-5A (TOPCON). All these items are measured under the dark room condition (no ambient light).

Measurement Condition: IL=16mA (each LED)

Definition of these measurement items is as follows:

*1) Setup of Measurement Equipment

The LCD module should be turn-on to a stable luminance level to be reached. The measurement should be executed after lighting Backlight for 20 minutes and in a dark room.

*2) Definition of Contrast Ratio

CR=ON (White) Luminance/OFF (Black) Luminance

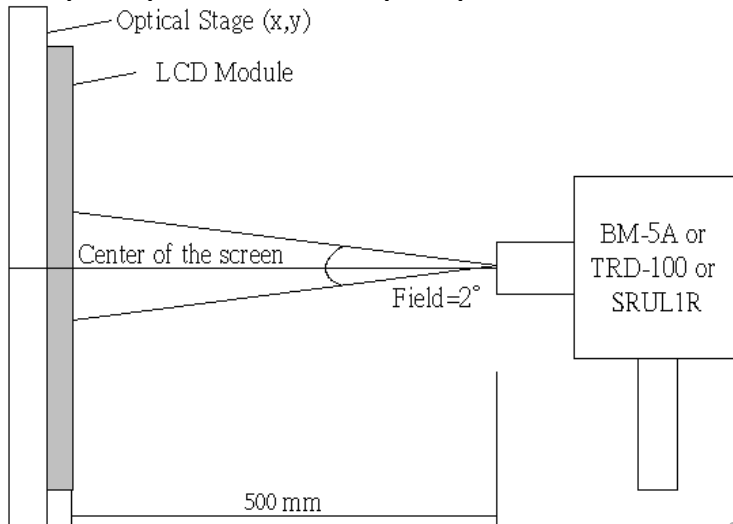

*3) Definition of Luminance and Luminance uniformity

Central luminance: The white luminance is measured at the center position "5" on the screen, see Fig.1 below.

5P Luminance (AVG): The white luminance is measured at measuring points 5 · 10 · 11 · 12 · 13, see Fig.1 below.

5P Uniformity: $\Delta L = (L_{min} / L_{max}) \times 100\%$

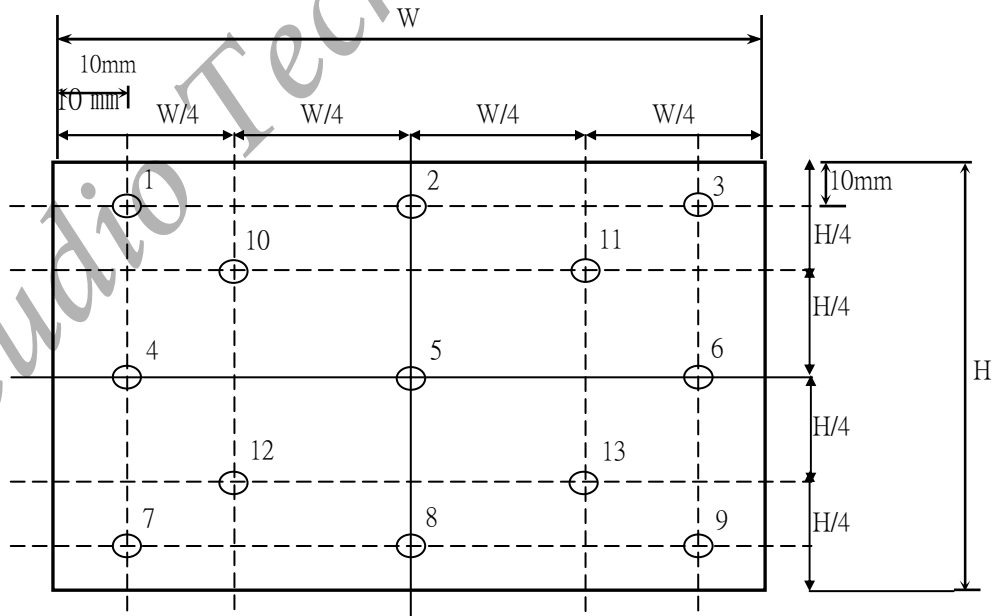
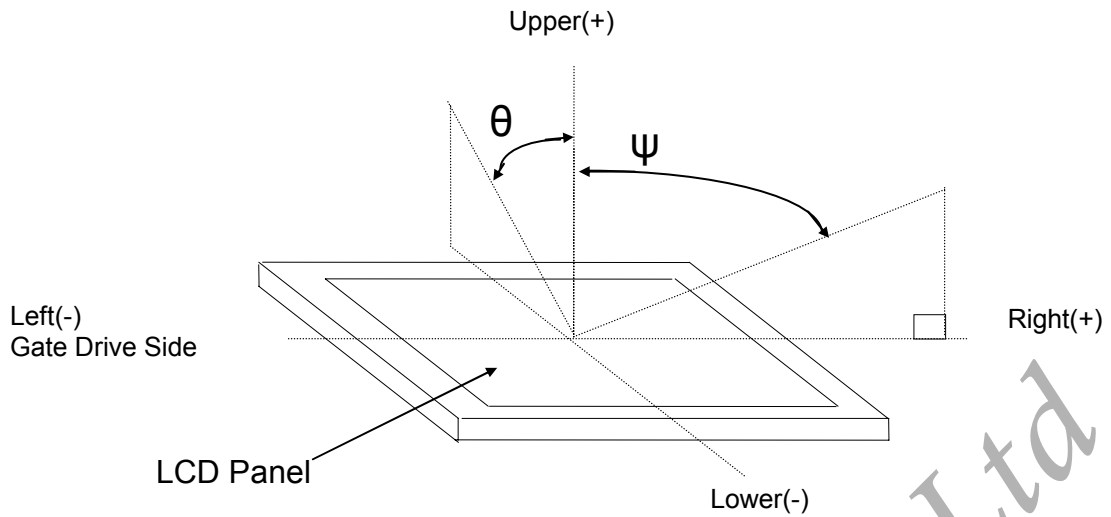
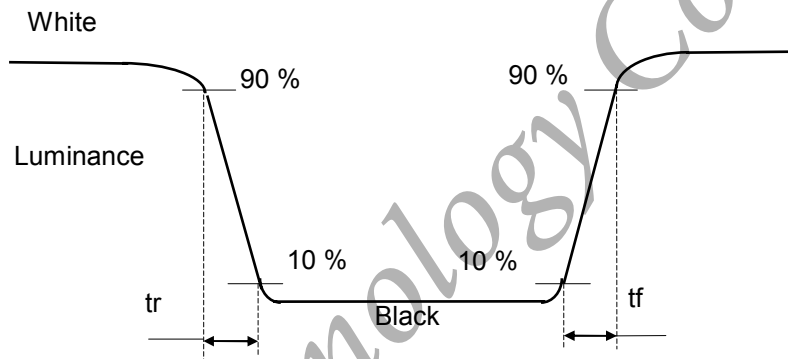

Fig.1 Measure point (Active area)

***4) Definition of view angle(θ , ψ)**



***5) Definition of response time**



***6) Crosstalk Modulation Ratio:**

$$CT = | Y_B - Y_A | / Y_{A \times} \times 100\%$$

Y_A , Y_B measure position and definition

Y_A means luminance at gray level 32(exclude gray level 0 pattern)

Y_B means luminance at gray level 32(include gray level 0 pattern)

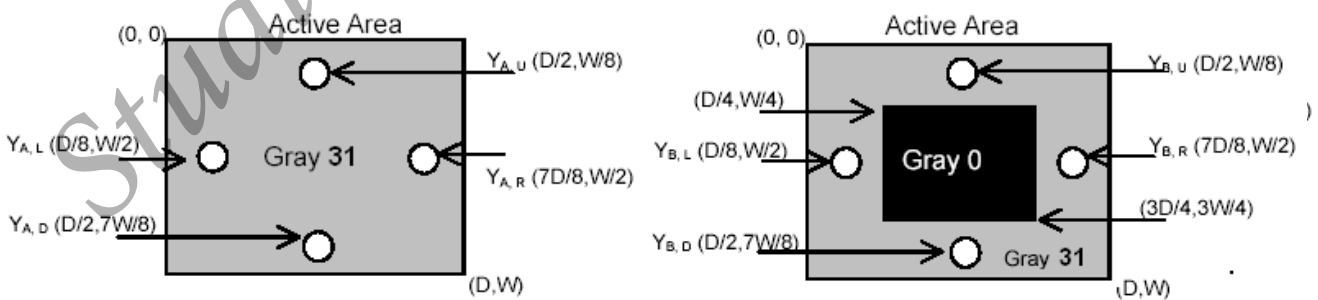

***7) Definition Gamma (VESA)**

Based on Customer Sample, take the average value as a standard center value and the variation range of gamma value caused by loop voltage error should be between +/- 0.2. the bellow figure shows how to obtain the gamma curve and γ (from gray level: 0、4、8-----60、63).

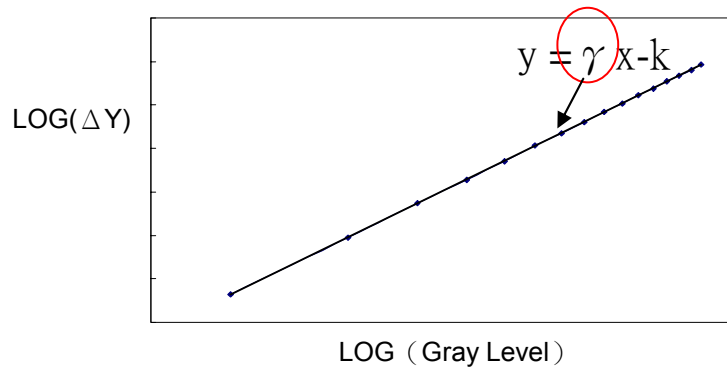

Studio Technology Co., Ltd

9. RELIABILITY TEST CONDITIONS

(A) Temperature · Humidity and Pressure

TEST ITEMS	CONDITIONS
High Temperature Operation	50° C ; 250Hrs
High Temperature Storage	65° C ; 250Hrs
High Temperature High Humidity Operation	40° C ; 95% RH ; 250Hrs
High Temperature High Humidity Storage	60° C ; 95% RH ; 48 Hrs
Low Temperature Operation	0° C ; 250 Hrs
Low Temperature Storage	-25° C ; 250 Hrs
Thermal Shock	-40° C (30 Mins)~65° C (30 Mins) , 100 CYCLE
Low Temperature Low Pressure Storage	0° C · 260hPa · 24 Hrs

(B) Shock & Vibration

TEST ITEMS	CONDITIONS
Shock (Non-Operation)	Shock level : 2058m/s ² (210G), Waveform : half sinusoidal wave, 2ms, 6 axis (± X, ± Y, ± Z) per cycle
Vibration (Non-Operation)	Vibration level : 14.7m/s ² (1.5G), sinusoidal wave (each x, y, z axis : 1hr, total 3hrs) Frequency range : 5~500 Hz Sweep speed : 0.5 Octave/min.

(C) ESD

	Surface discharge (Panel display area · Frame)		Electrics capacity of Connector
	Contact	Air	Contact
Capacity	150 pF	150 pF	200 pF
Resistance	330 Ω	330 Ω	0 Ω
Voltage	±8kV	±8kV/±15kV	±250 V
Interval	1 sec	1 sec	1 sec
Times(single point)	25	25	1

(D) MTBF without B/L : 200,000 Hrs(min) lifetime.

(E) Judgment standard

The judgment of the above test should be made as follow:

Pass : Normal display image with no obvious non-uniformity and no line defect.

Partial transformation of the module parts should be ignored.

Fail : No display image, obvious non-uniformity, or line defects.